

Document Number:

IEEE 802.16.1pp-00/05

Title:

Pilot-Assisted Frequency Domain Reciprocal Modulation for Microwave Channels with Dynamic Multipath

Date Submitted:

2000-01-12

Source:

Thomas H. Williams
Holtzman Inc.
6432 Fairways Dr.
Longmont, CO 80503

Tel: +1(303)444-6140
Fax: +1(303)444-7698
Email: tom@holtzmaninc.com

Venue:

Presented at the 5th 802.16 meeting in Dallas, TX.

Base Document:

IEEE 802.16.1pp-00/05 <http://grouper.ieee.org/groups/802/16/phy/contrib/802161pc-00_05.pdf>

Purpose:

Consideration as physical layer technology for inclusion in the proposed 802.16 standard.

Notice:

This document has been prepared to assist the IEEE 802.16. It is offered as a basis for discussion and is not binding on the contributing individual(s) or organization(s). The material in this document is subject to change in form and content after further study. The contributor(s) reserve(s) the right to add, amend or withdraw material contained herein.

Release:

The contributor acknowledges and accepts that this contribution may be made public by 802.16.

IEEE Patent Policy:

The contributor is familiar with the IEEE Patent Policy, which is set forth in the IEEE-SA Standards Board Bylaws <<http://standards.ieee.org/guides/bylaws>> and includes the statement: "IEEE standards may include the known use of patent(s), including patent applications, if there is technical justification in the opinion of the standards-developing committee and provided the IEEE receives assurance from the patent holder that it will license applicants under reasonable terms and conditions for the purpose of implementing the standard."

Pilot-Assisted Frequency Domain Reciprocal Modulation (FDRM) - Rev. 1

Tom Williams
Holtzman Inc.
Longmont, CO

Introducing FDRM

- Designed to deal with dynamic multipath distortion
- Uses two blocks that were encoded differently from the same information
- A multicarrier system that is related to OFDM
- Assumes that the same echoes distort each data block
- The two data blocks are processed together to find the unimpaired symbols
- The frequency response of the path can be measured and used for correcting future blocks or for averaging

Characteristics of FDRM

- First block is like OFDM, second is a frequency domain reciprocal to the first block, HC by HC
- Tolerant to dynamic multipath
- Operates in 0 dB echo environments
- Operates with dispersed echoes
- Tolerant to rapid fades
- Ideal for burst-mode
- Pilot assistance fixes problem of intolerance to phase-noise at microwave frequencies

Does 802.16 Need to Be Concerned with Big Echoes and Dynamic Multipath?

- Model is for line-of-site operation and line of site typically has low delay dispersion
- Requirements document also calls for multipath tolerance as well as interference from adjacent cells

Look Over Your Shoulder

- Sub - 11 GHz effort will be a high-volume (low cost) application
- What keeps a Sub-11 modem from operating in 10-60 GHz band?
 - Data Rates?
 - Applications or MAC?
 - Non-constant envelope or phase noise?
- Equipment designed for non-line of site can be just as efficient when operating line-of-site
- How are we going to distinguish ourselves?
- Will their success == our failure?

Multipath Distortion

- Also known as echoes or ghosts
- A linear distortion
- Copies of the same signal with different delays and attenuations - also diffuse echoes
- A weak echo increases BER in the presence of noise. A strong echo makes the data useless.
- A traditional solution is an adaptive equalizer, but adaptive equalizer's coefficients must be programmed to match the echoes
- Adaptive equalizer may use a training signal or blind equalization

Characteristics of Echoes at 10-60 GHz.

- Because distances between the transmitter and receiver are short, echo delay will also be short, therefore response ripple will change slowly vs. frequency
- Because the wavelength is short, if motion causes the echo to be dynamic, the phase of echo will change rapidly vs. time

Dynamic Multipath Distortion

- Caused by echoes or ghosts that change e.g. wind-blown foliage, tower sway, pedestrian traffic, birds, and repeaters
- Transmitter, receiver, or reflector may move
- The programming of the adaptive equalizer must change to match the moving echo
- At microwave frequencies change is very quick
- Rapid accurate reprogramming is difficult
- Noise increases the programming time
- Rapid signal fades also occur
- Sometimes no direct signal path is available

Echo Characterization

- Costs bandwidth
- Frequently required bandwidth is low
- Rate of change of echoes with time
- Rate of change of echoes with frequency
- Noise in the channel characterization increases intersymbol interference
- BER curves typically assume echo is gone

FDRM - Theory of Operation

Let $S(f)$ = normal transmitted signal in frequency domain and $H(f)$ = channel's frequency response. Therefore a normal received signal is:

$$X(f) = S(f) \cdot H(f)$$

If a reciprocal signal block is created:

$$R(f) = \frac{1}{S(f)}$$

A received reciprocal signal will be:

$$Y(f) = R(f) \cdot H(f) = \frac{H(f)}{S(f)}$$

Theory of Operation cont.

So the originally sent unimpaired signal can be found:

$$S(f) = \sqrt{\frac{X(f)}{Y(f)}} = \sqrt{\frac{S(f) \cdot H(f)}{\frac{H(f)}{S(f)}}} = \sqrt{S(f)^2}$$

Likewise, the channel's frequency response can be found by multiplying $X(f)$ by $Y(f)$:

$$X(f) \cdot Y(f) = S(f) \cdot H(f) \cdot \frac{H(f)}{S(f)} = H(f)^2$$

so the channel's frequency response is:

$$H(f) = \sqrt{H(f)^2}$$

Theory of Operation - cont.

- Approximately the same linear distortion must be applied to both blocks
- If any frequencies have low magnitude components computing the frequency domain reciprocal results in large (impractical) values
- OFDM fits the bill as a modulation with controlled energy at all frequencies (no low energy frequencies)
- Another method is single block FDRM. Normal carriers and reciprocal carriers are interleaved in the same block
- Assumption is that approximately the same echo afflicts adjacent carriers

Theory of Operation - cont.

- Noise affecting each block adds on a 10 log basis, but normal and reciprocal HCs are correlated and add on a 20 log basis
- Signal to noise ratio improved by 3 dB
- Noise in channel's frequency response is also reduced by 3dB
- Coherent interference from repeaters or other sectors is automatically canceled if delay is less than guard interval
- Square root has two solutions

Microwave Transmission

- Line of site is primary method for 10-60 GHz
- Wide-beam antenna at central site
- Narrow-beam antenna at remote site
- Impairments
 - Rain fade
 - dynamic multipath
 - co-channel interference
 - intermod products
 - random noise

Holtzman's Proposal

- FDRM/OFDM adapted to microwave with out-of-block pilots to tolerate phase noise and reciprocal transmissions for moving echoes
- Pilot assisted demodulation for both upstream and downstream
- Reciprocal transmission starts each upstream burst
- Reciprocal transmissions as-needed on downstream
- Stored coefficients will deghost harmonic carriers without accompanying reciprocals
- Transmissions are adapted to subscriber's path

Out-of-Block Pilot Signal

- Ka band phase noise from low cost transmitters is way too great for OFDM or FDRM
- Pilot is separated by vacant spectrum
- Another hot harmonic carrier
- Located at both upper band edge and at lower edge
- Used to demodulated the block transmission
 - Remove phase noise by mixing
 - Cancels the frequency offset
 - Vacant spectrum contains the frequency error and phase noise modulation

Antenna Diversity

- A second receive antenna is located a half wavelength further from the transmitter
- Deep fades are very unlikely to occur at the same frequencies on both antennas
- With OFDM or FDRM receiver can pick best antenna to use on a harmonic carrier by harmonic carrier basis
- With FDRM channel information, $H(f)$, makes antenna choice easy for each HC
- Signals from 2 antennas can be added using $H(f)$ data to align phases
- Coding overhead on OFDM or FDRM block can be lower

Proposed Constellations

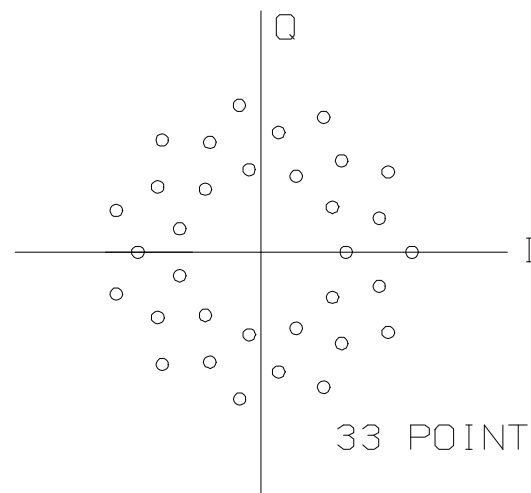
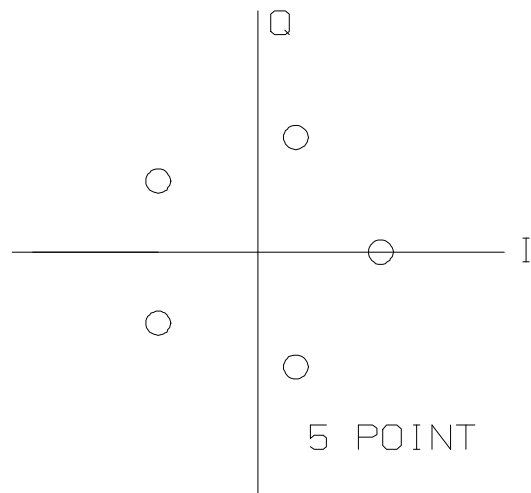
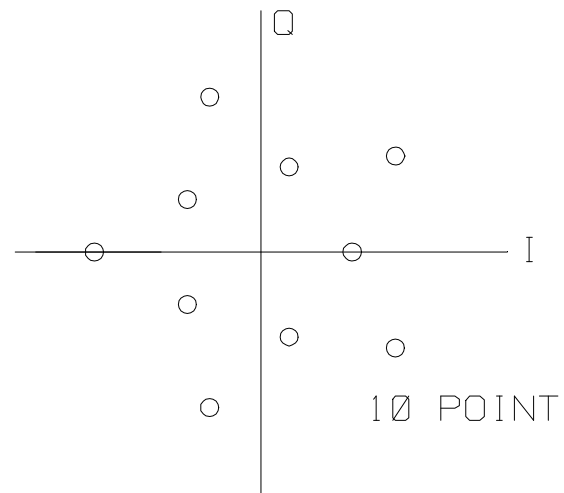
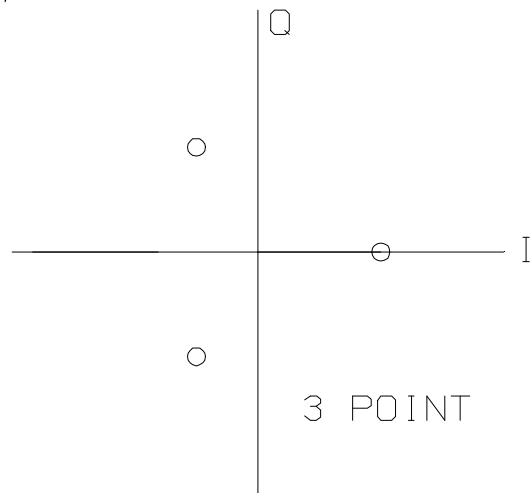

Proposed Time Plot of an Interleaved Burst

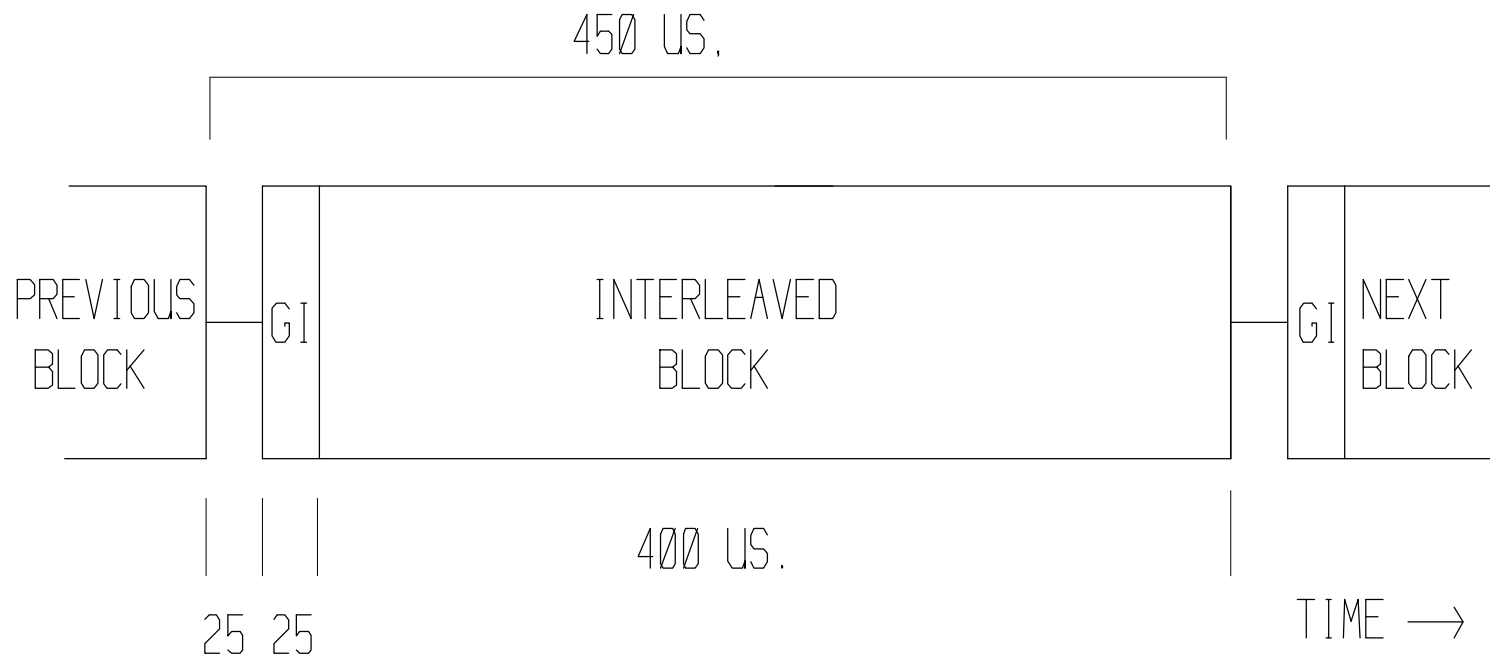

Proposed Spectral Plot

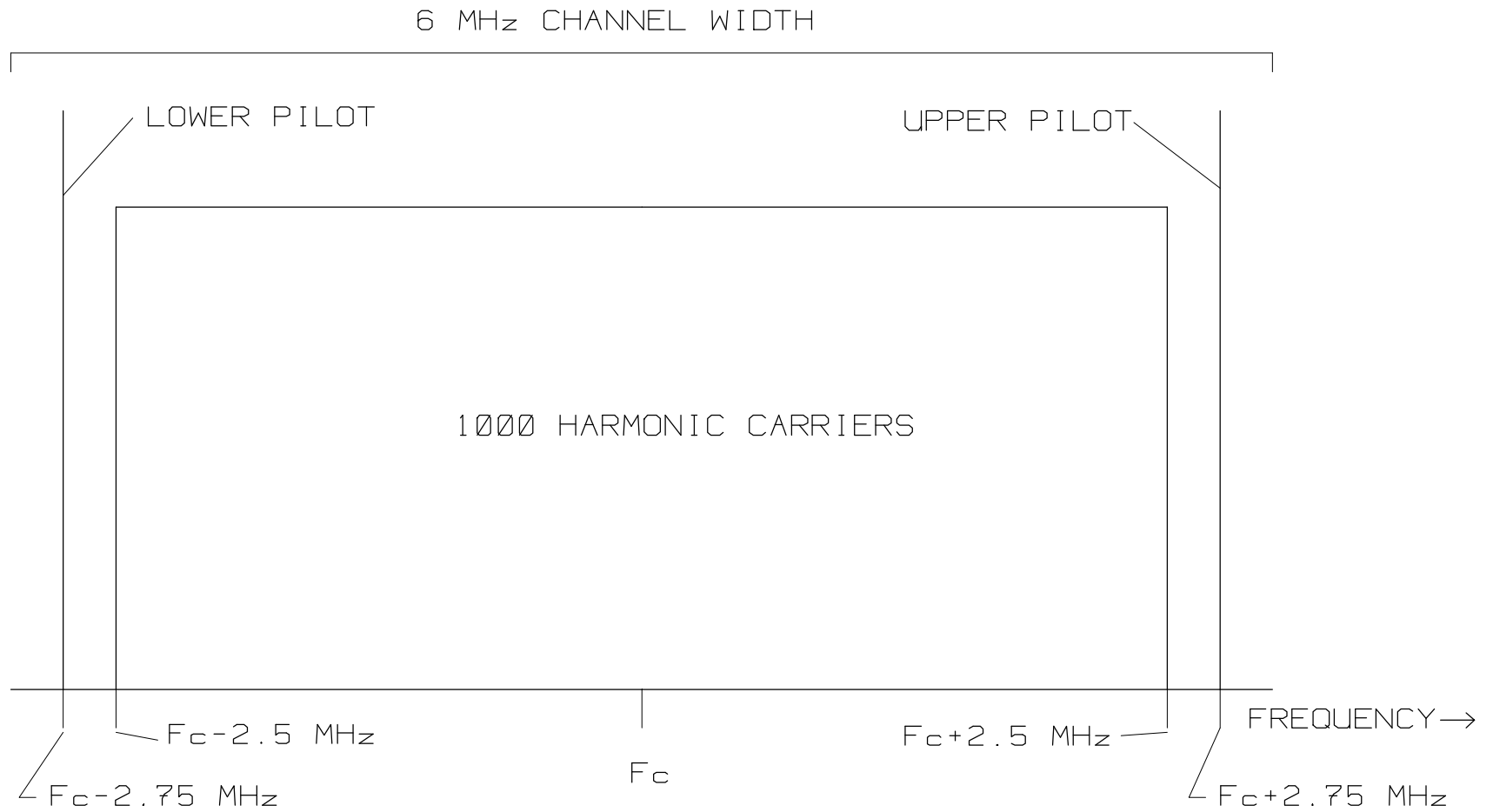

Alternate of a Sequential Burst Time Plot

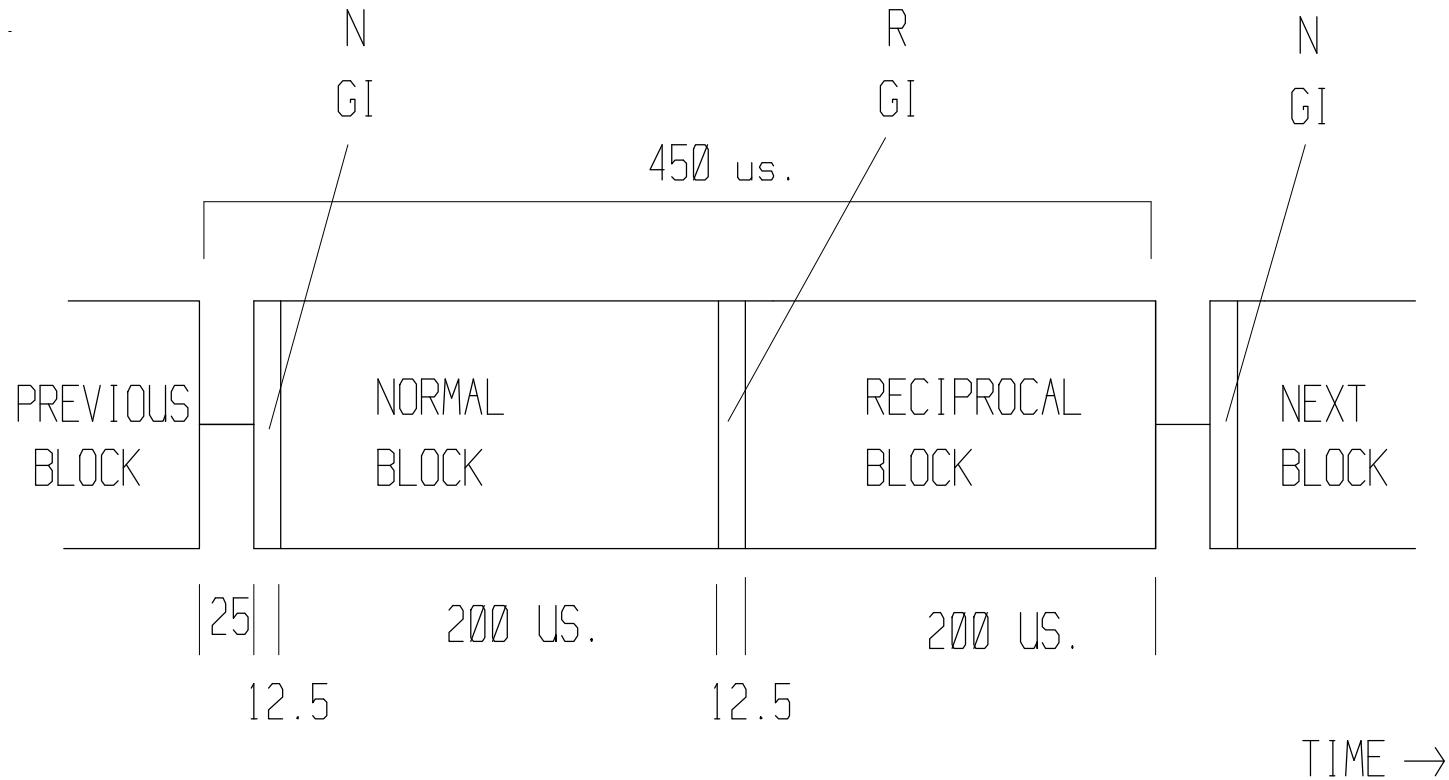

Block Diagram of Test Hardware

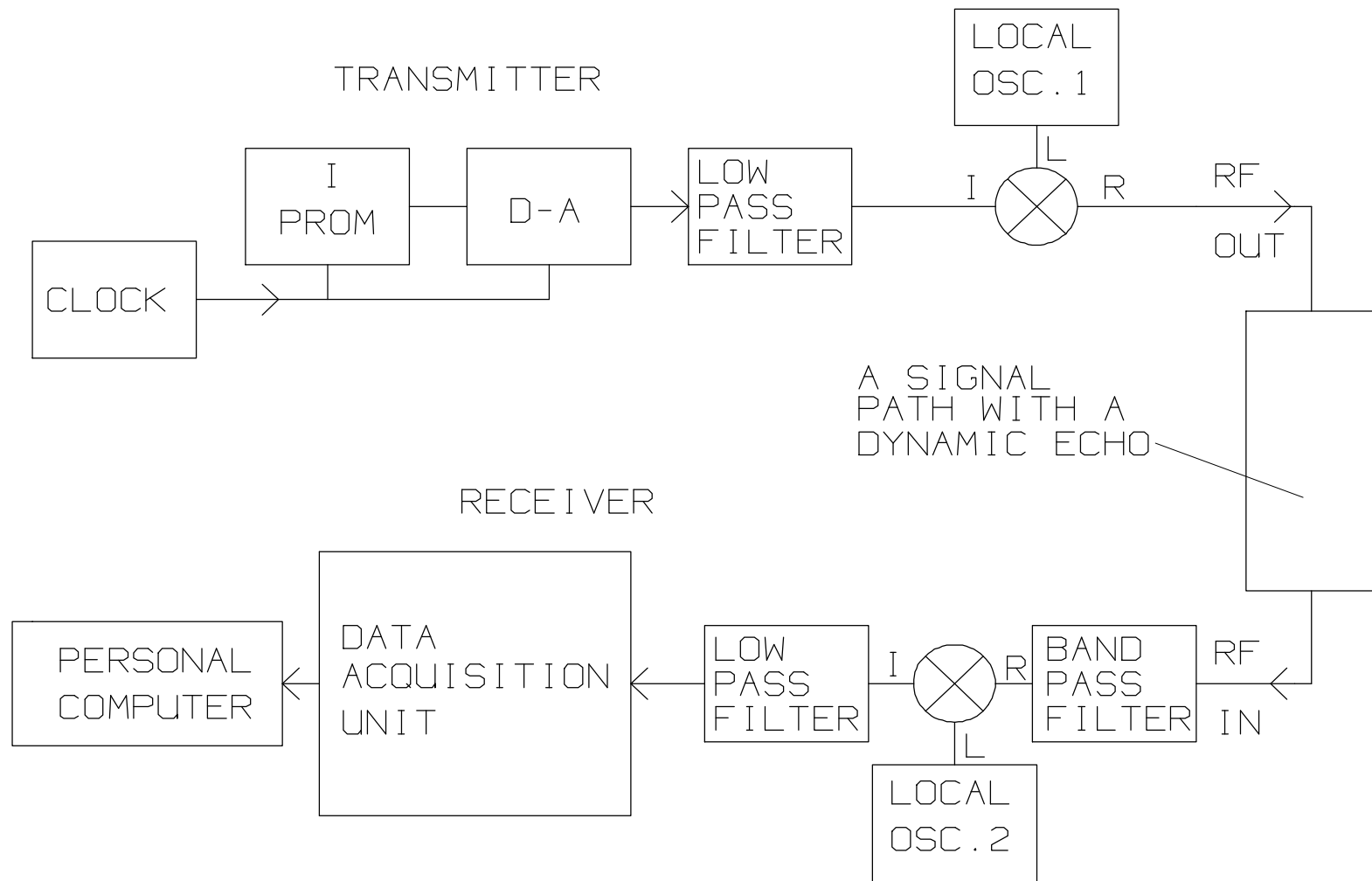

Test Results from Processing a Single Burst

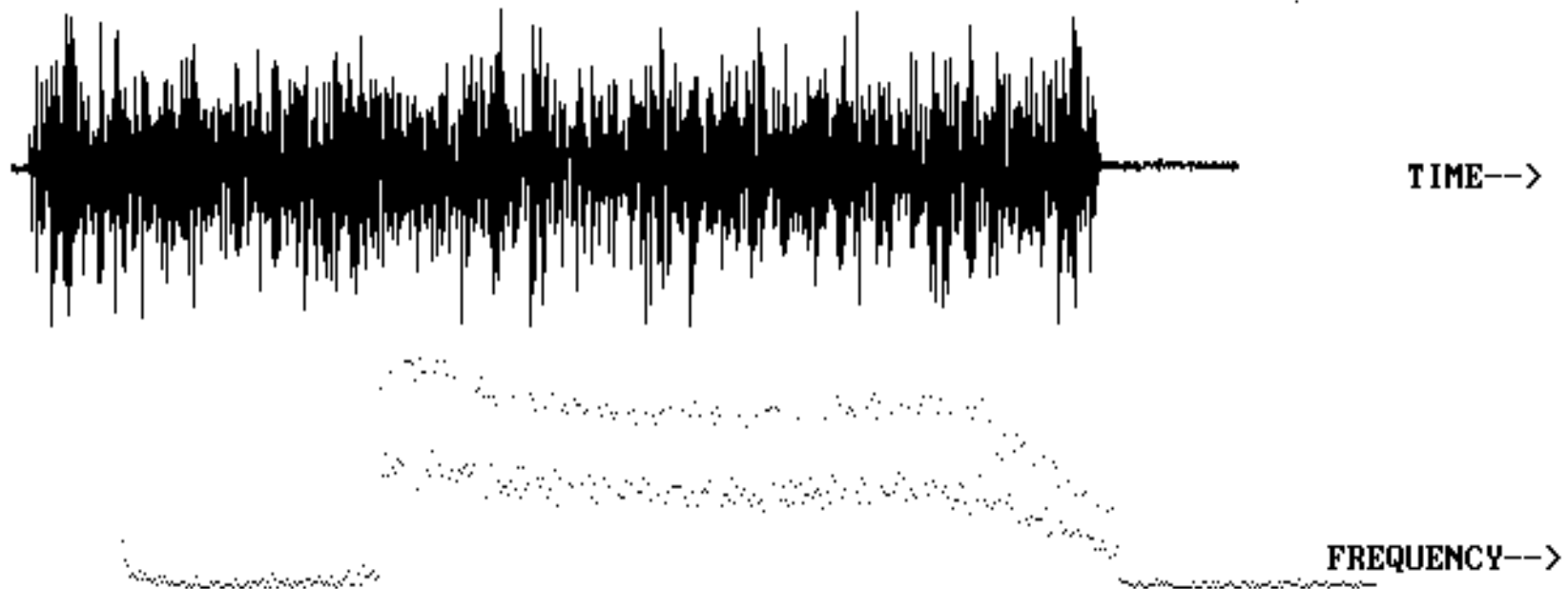

Constellation Spread from Random Noise

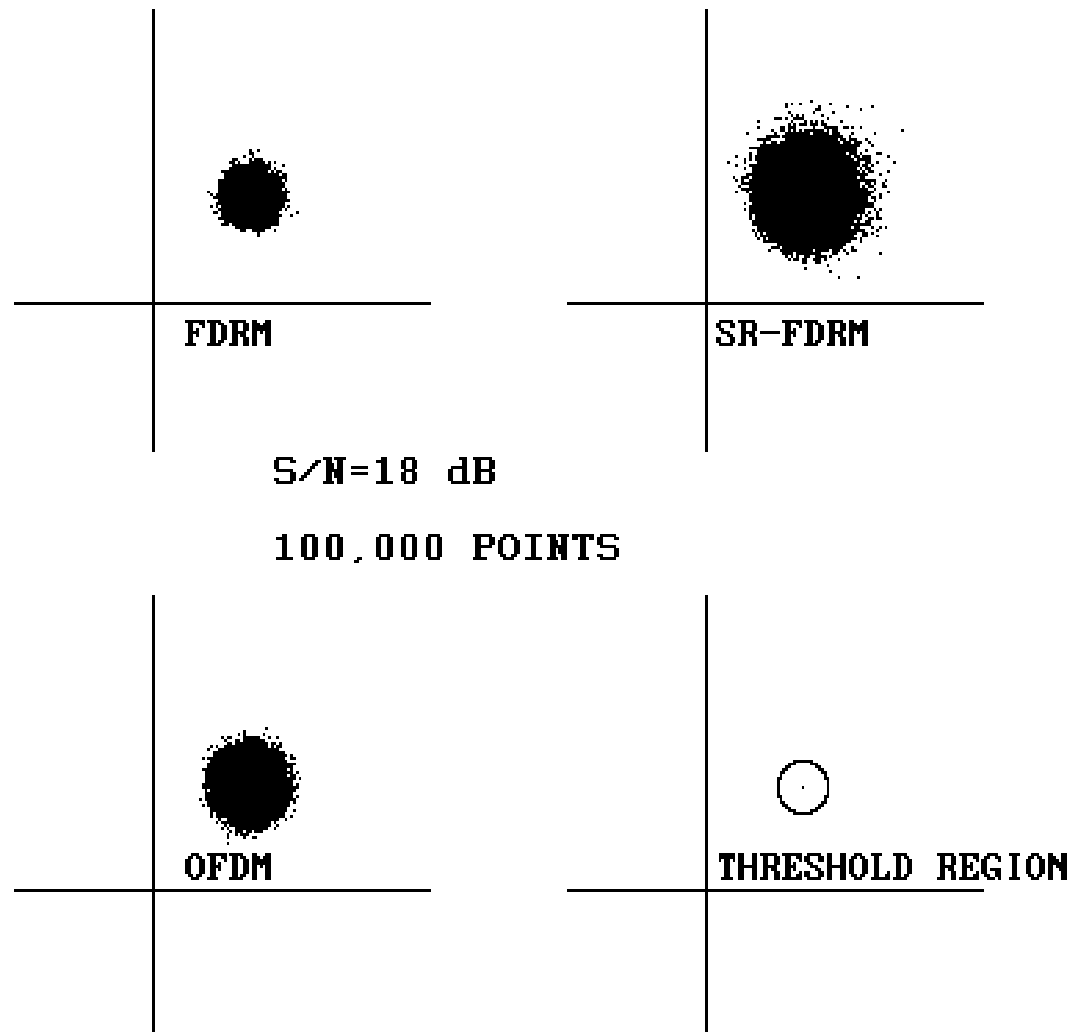

Symbol Error Rate vs. Carrier to Noise

Symbol Error Rate Before FEC

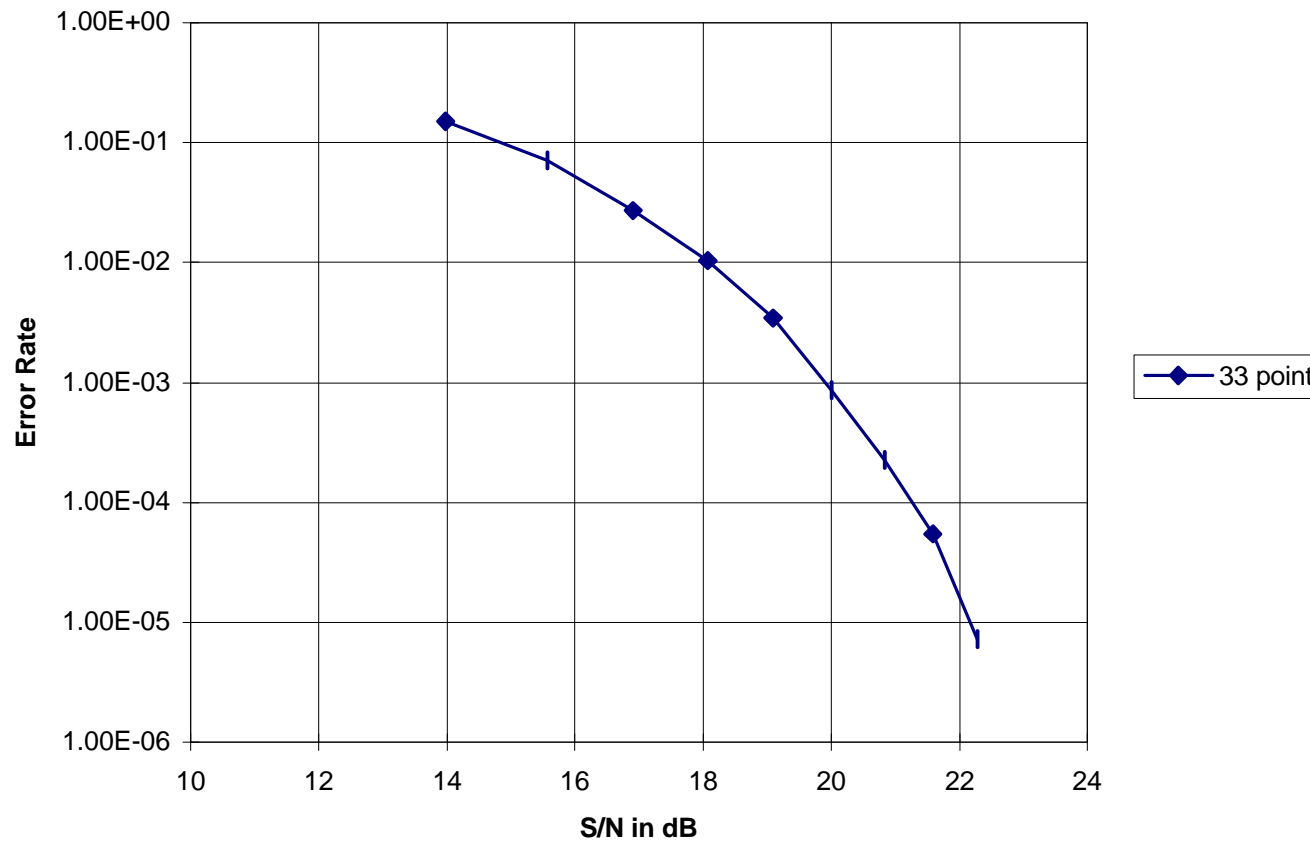

Observations from Test Data

- Technique works well
- Impairments from test setup corrected along with any echoes
- Easier to implement than OFDM
- Frequency differences between TX and RX LO's cause ISI (sequential blocks) or cause the processed constellation to be rotated (interleaved blocks)
- Forward error correction needed to recover symbols lost in deep fades.
- Signal adds on a 20 log basis while random noise adds on a 10 log basis. Result is a 3 dB better S/N ratio.

Conclusions

- FDRM = frequency domain reciprocal modulation
- Pilot assistance for phase noise
- Two blocks of data that are reciprocal to each other in the frequency domain are sent in an interleaved block
- The same echoes contaminate both blocks. The blocks are processed together at the receiver
- Linear distortion is automatically canceled as an intrinsic property of the modulation
- Reciprocal blocks sent as often as necessary

Contact Information:

Thomas H. Williams

President

Holtzman Inc.

6423 Fairways Dr.

Longmont, CO 80503

e-mail: tom@holtzmaninc.com

phone: 303-444-6140

fax: 303-444-7698

Patents Pending