

**THIS IS THE P802.16j BASELINE DOCUMENT.
THIS IS NOT AN IEEE DRAFT STANDARD.**

**Baseline Document for Draft Standard for
Local and Metropolitan Area Networks**

Part 16: Air Interface for Fixed and Mobile Broadband Wireless Access Systems

Multihop Relay Specification

Sponsor

~~LAN-MAN Standards Committee~~

~~of the~~

~~IEEE Computer Society~~

Prepared by the Relay Task Group of IEEE 802.16

Abstract: This document specifies OFDMA physical layer and medium access control layer enhancements to IEEE Std. 802.16 for licensed bands to enable the operation of relay stations.

Keywords:

~~Copyright © 2006 by the Institute of Electrical and Electronics Engineers, Inc.~~

~~345 East 47th Street~~

~~New York, NY 10017, USA~~

~~All rights reserved.~~

~~All rights reserved. This document is an unapproved draft of a proposed IEEE Standard. As such, this document is subject to change. USE AT YOUR OWN RISK! Because this is an unapproved draft, this document must not be utilized for any conformance/compliance purposes. Permission is hereby granted for IEEE Standards Committee participants to reproduce this document for purposes of IEEE standardization activities only. Prior to submitting this document to another standards development organization for standardization activities, permission must first be obtained from the Manager, Standards Licensing and Contracts, IEEE Standards Activities Department. Other entities seeking permission to reproduce this document, in whole or in part, must obtain permission from the Manager, Standards Licensing and Contracts, IEEE Standards Activities Department.~~

~~IEEE Standards Department~~

~~Copyright and Permissions~~

~~445 Hoos Lane, P.O. Box 1331~~

~~Piscataway, NJ 08855-1331, USA~~

This page is left intentionally blank

The Institute of Electrical and Electronics Engineers, Inc.
3 Park Avenue, New York, NY 10016-5997, USA

Copyright © 2005 by the Institute of Electrical and Electronics Engineers, Inc.
All rights reserved. Published xx Month 2005. Printed in the United States of America.

IEEE is a registered trademark in the U.S. Patent & Trademark Office, owned by the Institute of Electrical and Electronics Engineers, Incorporated.

Print: ISBN 0-7381-xxxx-xSHxxxx
PDF: ISBN 0-7381-xxxx-xSSxxxx

No part of this publication may be reproduced in any form, in an electronic retrieval system or otherwise, without the prior written permission of the publisher.

Introduction

(This introduction is not part of the IEEE P802.16j, Draft amendment to IEEE Standard for Local and Metropolitan Networks Part 16: Air Interface for Fixed and Mobile Broadband Wireless Access Systems - Multihop Relay Specifications).

Participants

~~This document was developed by the IEEE 802.16 Working Group on Broadband Wireless Access, which develops the WirelessMANTM Standard for Wireless Metropolitan Area Networks.~~

IEEE 802.16 Working Group Officers

[Editor's Note: Insert list of WG Officers]

~~Primary development was carried out by the Working Group's Relay Task Group.~~

TG Officers

[Editor's Note: Insert list of TG Officers]

This page is left intentionally blank

Contents

| | | |
|-----------|---|----|
| 1. | Overview..... | 2 |
| 1.1 | Scope..... | 2 |
| 1.2 | Purpose..... | 2 |
| 1.3 | Frequency bands | 2 |
| 1.3.4 | Air interface nomenclature and PHY compliance | 2 |
| 1.4 | Reference model | 2 |
| 1.4.2 | Relaying reference model | 2 |
| 2. | References..... | 2 |
| 3. | Definitions | 2 |
| 4. | Abbreviations and acronyms | 3 |
| 6. | MAC common part sublayer..... | 3 |
| 6.1 | PMP | 3 |
| 6.1.1 | Relaying extension..... | 3 |
| 6.3 | Data/Control plane | 3 |
| 6.3.1 | Addressing and connections | 3 |
| 6.3.1.3 | Addressing and connections for relay support..... | 3 |
| 6.3.2 | MAC PDU formats | 4 |
| 6.3.2.1 | MAC header formats | 4 |
| 6.3.2.2 | MAC subheaders and special payloads | 4 |
| 6.3.2.3 | MAC management messages..... | 4 |
| 6.3.3 | Construction and transmission of MAC PDUs..... | 13 |
| 6.3.3.2 | Concatenation | 13 |
| 6.3.3.8 | MMR construction and transmission of MAC PDUs..... | 13 |
| 6.3.4 | ARQ mechanism..... | 14 |
| 6.3.4.6 | ARQ operation | 14 |
| 6.3.5 | Scheduling services..... | 14 |
| 6.3.6 | Bandwidth allocation and request mechanisms | 14 |
| 6.3.6.7 | Relay support for scheduling bandwidth request and allocation mechanisms | 14 |
| 6.3.7 | MAC support of PHY | 19 |
| 6.3.7.3 | DL-MAP | 19 |
| 6.3.7.4 | UL-MAP | 19 |
| 6.3.7.7 | Optional MAC support of the PHY for relaying | 19 |
| 6.3.7.7 | Optional MAC support of the PHY for relaying | 20 |
| 6.3.8 | Contention resolution..... | 20 |
| 6.3.9 | Network entry and initialization | 20 |
| 6.3.9.16 | Support for network entry and initialization in relay mode..... | 20 |
| 6.3.10 | Ranging..... | 28 |
| 6.3.10.3 | OFDMA based ranging..... | 28 |
| 6.3.11 | Update of channel descriptors..... | 28 |
| 6.3.12 | Assigning Ss to multicast groups..... | 28 |
| 6.3.13 | Establishment of multicast and broadcast transport connections | 28 |
| 6.3.14 | QoS | 28 |
| 6.3.14.2 | Service flows..... | 28 |
| 6.3.14.10 | Tunnel Service Flows | 28 |
| 6.3.17 | MAC support for HARQ | 29 |

| | | |
|-----------|---|----|
| 6.3.18 | DL CINR report operation | 29 |
| 6.3.18.3 | Relay station DL CINR report operations | 29 |
| 6.3.19 | optional Band AMC operations using 6-bit CQICH encoding | 29 |
| 6.3.21 | Sleep mode for mobility-supporting MS | 29 |
| 6.3.21.7 | Relay support for MS sleep mode | 29 |
| 6.3.22 | MAC layer handover procedures | 30 |
| 6.3.22.1 | Network topology acquisition | 30 |
| 6.3.22.4 | Mobile relay station handover | 30 |
| 6.3.22.5 | MS handover procedure involving RS | 30 |
| 6.3.23 | Multicast and broadcast services (MBS) | 31 |
| 6.3.23.1 | Single-BS access | 31 |
| 6.3.23.2 | Multi-BS access | 31 |
| 6.3.23.3 | MBS in MR network | 31 |
| 6.3.24 | MS Idle Mode (optional) | 31 |
| 6.3.24.10 | MRS Paging Group Update | 32 |
| 6.3.24.11 | Network Re-Entry for MRS Paging Group Update | 33 |
| 6.3.25 | Relay path management and routing | 33 |
| 6.3.26 | Relay station neighborhood discovery | 33 |
| 6.3.27 | Interference measurement for MR | 33 |
| 7. | Security sublayer | 34 |
| 7.1 | Architecture | 34 |
| 7.2 | PKM protocol | 34 |
| 7.3 | Dynamic SA creation and mapping | 34 |
| 7.4 | Key usage | 34 |
| 7.5 | Cryptographic methods | 34 |
| 7.6 | Certification profile | 34 |
| 7.7 | Pre-Authentication | 34 |
| 7.8 | PKMv2 | 34 |
| 8. | PHY | 34 |
| 8.4 | WirelessMAN-OFDMA PHY layer | 34 |
| 8.4.1 | Introduction | 34 |
| 8.4.4 | Frame structure | 34 |
| 8.4.4.7 | Frame structure of MR-BS and RS | 34 |
| 8.4.4.8 | Relaying frame structure | 38 |
| 8.4.5 | Map message fields and IEs | 38 |
| 8.4.7 | OFDMA ranging | 38 |
| 8.4.8 | Space-Time Coding (optional) | 38 |
| 8.4.8.1 | Cooperative Relaying | 38 |
| 8.4.9 | Channel coding | 39 |
| 8.4.10 | Control mechanisms | 39 |
| 8.4.10.4 | Power control in MR networks | 39 |
| 8.4.11 | Channel quality measurements | 40 |
| 8.4.12 | Transmitter requirements | 40 |
| 8.4.13 | Receiver requirements | 40 |
| 8.4.14 | Frequency control requirements | 40 |
| 8.4.15 | Optional HARQ support | 40 |
| 9. | Configuration | 40 |
| 9.3 | MR-BS configuration | 40 |

| | | |
|-------------|---|----|
| 9.4 | RS configuration | 40 |
| 10. | Parameters and constants | 40 |
| 10.1 | Global values | 40 |
| 10.2 | PKM parameter values | 41 |
| 10.3 | PHY-specific values | 41 |
| 10.3.5 | Relay mode PHY parameters and definitions | 41 |
| 10.4 | Well-known addresses and identifiers | 41 |
| 11. | TLV Encodings | 43 |
| 11.5 | RNG-REQ message encodings | 43 |
| 11.6 | RNG-RSP message encodings | 44 |
| 11.19.1 | CDMA Codes TLV | 45 |
| 11.20.x | Tunnel CID and Management Tunnel CID | 45 |
| 11.XMR | Code Report management message encodings | 46 |
| 11.XXMR_NBR | -INFO Management Message Encoding | 46 |

This page is left intentionally blank

List of Tables

| | |
|---|----|
| Table 14—MAC Management messages | 4 |
| Table 109z—RS-CDC message format | 6 |
| Table xx—MR Code Report(MR_CODE-REP) message Format | 13 |
| Table 342—Parameters and constants | 40 |
| Table 345—CIDs | 42 |
| Table 364—RNG-REQ message encodings | 43 |
| Table 367—RNG-RSP message encodings | 44 |

This page is left intentionally blank

List of Figures

| | |
|---|----|
| Figure X.01—Reducing latency in relaying traffic by transmitting BW req. header on R-UL before packets arrive | 16 |
| Figure x.02—Reducing latency in relaying traffic via RS polling | 17 |
| Figure x. 03—Reducing latency in relaying traffic by early transmission of BW request ranging code on the R-UL | 18 |
| Figure XXX —Ranging and automatic adjustments procedure in MR mode | 21 |
| Figure XXX —MS CDMA Initial Ranging -- Access Transparent RS | 22 |
| Figure XXX—MS Initial Ranging -- Access Transparent RS | 22 |
| Figure XXX —MS CDMA Initial Ranging with Transparent RS -- MR-BS | 23 |
| Figure <xxx>—MS Initial Ranging with Transparent RS-- MR-BS | 24 |
| Figure <XXX>02—Ranging and automatic adjustments procedure in MR mode | 26 |
| Figure <XXX>03—Ranging and automatic adjustments procedure with optional availability check at MR-BS in MR mode | 27 |
| Figure <xxx>—Example of configuration for an in-band transparent relay frame structure..... | 35 |
| Figure <xxx>—Example of minimum configuration for an in-band non-transparent relay frame structure | 37 |

This page is left intentionally blank

1 **Baseline Document for Draft Standard for**
2 **Local and Metropolitan Area Networks**
3
4
5
6
7

8 **Part 16: Air Interface for Fixed and**
9 **Mobile Broadband Wireless Access**
10 **Systems**
11
12
13
14

15 **Multihop Relay Specification**
16
17
18
19
20
21
22
23

24 NOTE-The editing instructions contained in this amendment define how to merge the material contained
25 herein into the existing base standard and its amendments to form a comprehensive standard.
26

27 The editing instructions are shown *bold italic*. Four editing instructions are used: *change*, *delete*, *insert*, and
28 *replace*. *Change* is used to make small corrections in existing text or tables. The editing instruction specifies
29 the location of the change and describes what is being changed by either by using ~~striethrough~~ (to remove
30 old material) or underscore (to add new material). *Delete* removes existing material. *Insert* adds new
31 material without disturbing the existing material. Insertions may require renumbering. If so, renumbering
32 instructions are given in the editing instruction. *Replace* is used to make large changes in existing text,
33 subclauses, tables, or figures by removing existing material and replacing it with new material. Editorial
34 notes will not be carried over into future editions because the changes will be incorporated into the base
35 standard.
36
37
38
39
40
41
42
43
44
45
46
47
48
49
50
51
52
53
54
55
56
57
58
59

1. Overview

1.1 Scope

This document specifies OFDMA physical layer and medium access control layer enhancements to IEEE Std 802.16 for licensed bands to enable the operation of relay stations. Subscriber station specifications are not changed.

1.2 Purpose

The purpose of this amendment is to enhance coverage, throughput and system capacity of 802.16 networks by specifying 802.16 multihop relay capabilities and functionalities of interoperable relay stations and base stations.

1.3 Frequency bands

1.3.4 Air interface nomenclature and PHY compliance

1.4 Reference model

Insert new subclause 1.4.2:

1.4.2 Relaying reference model

2. References

3. Definitions

Insert the following at the end of section 3:

3.88 MR-BS frame: Frame structure for DL transmission/UL reception by MR-BS

3.89 RS frame: Frame structure for DL transmission/UL reception by RS.

3.90 DL Access_Zone: A portion of the DL sub-frame in the MR-BS/RS frame used for MR-BS/RS to MS transmission

3.91 UL Access_Zone: A portion of the UL sub-frame in the MR-BS/RS frame used for MS(s) to MR-BS/RS transmission

3.92 DL Relay_Zone: A portion of the DL sub-frame in the MR-BS/RS frame used for MR-BS/RS to RS transmission

3.93 UL Relay_Zone: A portion of the UL sub-frame in the MR-BS/RS frame used for RS to MR-BS/RS transmission

1 **3.94 T-CID(Tunnel CID):** A unique identifier taken from the connection identifier (CID) address space
 2 that uniquely identifies transport tunnel connections between the MR-BS and RSs.
 3

4 **3.95 MT-CID(Management Tunnel CID):** A unique identifier taken from the connection identifier (CID)
 5 address space that uniquely identifies management tunnel connections between the MR-BS and RSs.
 6

7 **3.96 Access link:** An 802.16 radio link that originates or terminates at an MS. The access link is either an
 8 uplink or downlink as defined in IEEE Std. 802.16-2004 and IEEE Std. 802.16e-2005.
 9

10 **3.97 Relay link (R-Link):** An IEEE Std. 802.16j radio link between an MR-BS and a RS or between a pair of
 11 RSs. This can be a relay uplink or downlink.
 12
 13

14 **4. Abbreviations and acronyms**

15
 16
 17
 18
 19 *Insert the followings at the end of section 4:*

20
 21 R-TTG Relay-TTG

22
 23 R-RTG Relay-RTG

24
 25 R-FCH Relay-FCH

26
 27 R-MAP Relay MAP

28 29 30 31 **6. MAC common part sublayer**

32 33 34 **6.1 PMP**

35
 36
 37 *Insert new subclause 6.1.1:*

38 39 **6.1.1 Relaying extension**

40 41 42 **6.3 Data/Control plane**

43 44 45 **6.3.1 Addressing and connections**

46
 47
 48 *Insert new subclause 6.3.1.3:*

49 50 **6.3.1.3 Addressing and connections for relay support**

51
 52 Addressing and connections as perceived by the SS/MS are defined in the same manner as in the PMP mode.
 53 Please refer to section 6.3.1.1 for the specification. This section specifies the additional addressing and con-
 54 nection definitions that apply to relay functions. Each air interface in the RS shall have a 48-bit universal
 55 MAC address, as defined in IEEE Std 802@-2001. This address uniquely defines the air interface of the RS
 56 from within the set of all possible vendors and equipment types. It is used during the initial ranging process
 57 to establish the appropriate connections for an RS. It is also used as part of the authentication process by
 58 which the MR-BS and RS each verify the identity of the other.
 59

RSs that broadcast a preamble, FCH, and DL Map shall be assigned a unique Base Station ID. The format of the Base Station ID is defined in section 6.3.2.3.2.

In MR networks, connections can span multiple hops. Connections shall be identified by the connection ID (CID) as specified in section 6.3.1.1. CIDs are unique within an MR cell. In MR networks all connection types specified in PMP mode shall be supported between the MR-BS and MS. In MR networks, these connections may pass through one or more RSs.

Basic and primary management connections shall be established between the MR-BS and all RSs within the MR cell. These connections shall be used for the exchange of management messages between the MR-BS and RS and may pass through one or more intermediate RSs.

An additional type of connection called a tunnel connection may be established between the MR-BS and an RS. Tunnel connections shall be used for transporting MPDUs from one or more connections that terminate in the MR-BS and pass through the RS. It is not required that all connections must pass through a tunnel connection. MPDUs from connections that do not pass through a tunnel are forwarded based on the CID of the connection. Tunnel connections may pass through one or more intermediate RSs. There shall be two types of tunnel connections. Management tunnel connections shall be used for transporting MPDUs from management (basic, primary, or secondary) connections. Management tunnel connections shall not be used to transport MPDUs from transport connections. Management tunnel connections shall be identified using the MT-CID. Transport tunnel connections shall be used for transporting MPDUs from transport connections. Transport tunnel connections shall not be used to transport MPDUs from management connections. Transport tunnel connections shall be identified using the T-CID.

6.3.2 MAC PDU formats

6.3.2.1 MAC header formats

6.3.2.2 MAC subheaders and special payloads

6.3.2.3 MAC management messages

Change Table 14 as indicated:

Table 14—MAC Management messages

| | | | |
|----------|--------|--|-------|
| 67 | RS-CDC | Cooperative diversity configuration for RS message | Basic |
| 6768-255 | | Reserved | |

6.3.2.3.5 Ranging Request(RNG-REQ) message

Insert the following text at the end of subclause 6.3.2.3.5:

The following parameter may be included in the RNG-REQ message when the RS is attempting to perform

1 [network entry, re-entry, association or handover:](#)

2
3
4 **RS Type TLV (see 11.5)**

5
6 [The following parameter shall be included in the RNG-REQ message when the RS is attempting to perform](#)
7 [Paging Group Update:](#)

8
9 **RS MAC Address**

10 RS MAC Address shall be included

11
12
13 **Ranging Purpose Indication**

14 Presence of item in message indicates RS action as follows: If Bit #2 is set to 1, in combination
15 with RS Paging Group ID indicates the RS is currently attempting to Paging Group Update pro-
16 cess.
17

18
19 **Paging Group ID (16 bit)**

20 One or more logical affiliation grouping of MRS (see 6.3.2.3.56).

21
22
23 [The following parameter may be included in the RNG-REQ message when the RS is attempting to perform](#)
24 [Paging Group Update and the RS has a valid HMAC/CMAC Tuple necessary to expedite security authenti-](#)
25 [cation.](#)

26
27 **HMAC/CMAC Tuple (see 11.1.2)**

28 The HMAC/CMAC Tuple shall be the last attribute in the message.
29
30
31
32

33
34 **6.3.2.3.6 Ranging Response(RNG-RSP) message**

35
36
37 *Insert the following text at the end subclause 6.3.2.3.6:*

38
39
40 [When a MMR-BS sends RNG-RSP message in response to a RNG-REQ message containing MRS Paging](#)
41 [Group ID, the MMR-BS shall include the following TLV parameter in the RNG-RSP message:](#)

42
43 **Paging Group Update Response**

44 Response to Paging Group Update Request:

45 0b00=Failure of Paging Group Update. The MRS shall perform Network Re-entry

46 0b01=Success of Paging Group Update

47 0b10, 0b11: Reserved
48
49
50

51
52 [The following parameter may be included in the RNG-RSP message for the purpose of assigning RS CDMA](#)
53 [ranging codes to an RS:](#)

54
55 **RS CDMA Codes TLV (see 11.19)**

56
57
58
59 *Insert new subclause 6.3.2.3.62:*

6.3.2.3.62 Cooperative diversity configuration for RS (RS-CDC) message

An RS CDC is sent by a MR-BS to an RS to configure the cooperative diversity mode.

Table 109z—RS-CDC message format

| Syntax | Size | Notes |
|-----------------------------|--------|--|
| RS-CDC_Message_Format() { | | |
| Management Message Type=67? | 8 bits | |
| Antenna Assignment | 4 bits | Bit#0: Antenna #0 Bit#1: Antenna #1 Bit#2: Antenna #2 Bit#3: Antenna #3 |
| RS Encoding Method | 1 bit | 0b0 = No encoding 0b1 = Encoding |
| Reserved | 3 bits | Reserved |
| } | | |

An MR-BS shall generate RS-CDC message in the form shown in Table 109z, including the following parameters:

Antenna Assignment

Indicates which antenna the corresponding RS should play the role of. For example, if this field is a 0b1000, the relay station shall be playing the role of Antenna #0. As another example, in case the RS has two antennas and this field is 0b1100, each antenna of the RS shall be playing the role of Antenna #0 and #1, respectively. Each antenna will transmit pilots according to Figure 245, 247, 251, 251a, based on the chosen STC in the corresponding STC_DL_Zone_IE. If no transmit diversity is used (STC='0b00' in STC_DL_Zone_IE), all active antennas use non-STC pilot patterns.

RS Encoding method

No Encoding indicates that the relay station retransmits the data symbols, in order, without modification. Note that the pilot transmission must still be obeyed, according to the antenna assignment and STC. Encoding indicates that the symbols [S1, S2], or [S1, S2, S3, S4], or [S1, S2, S3, S4, S5, S6, S7, S8] are transmitted by the BS and received by the RS, in that order, and re-encoded by the RS according to the chosen STC defined in 8.4.8.1.4 and 8.4.8.2.3. The STC is based on the parameters in the corresponding STC_DL_Zone IE. For 2 transmit antennas using Matrix A, Encoding follows the coding scheme for code A in 8.4.8.1.4. That is, it represents the operation [S1 S2] .. [S1 -S2*] for Antenna #0, [S2 S1*] for Antenna #1. For 4 transmit antennas using Matrix A, Encoding follows the coding scheme for code A in 8.4.8.2.3. That is, it represents the operation [S1 S2 S3 S4] .. [S1 -S2* 0 0] for Antenna #0, [S2 S1* 0 0] for Antenna #1, [0 0 S3 -S4*] for Antenna #2, [0 0 S4 S3*] for Antenna #3. For 2 transmit antennas using Matrix B, Encoding follows the coding scheme for code B in 8.4.8.1.4. This is a mapping from two symbols to one symbol, i.e. [S1 S2] .. [S1], [S2] for Antenna #0, #1 respectively. For 4 transmit antennas using Matrix B, Encoding follows the coding scheme for code B in 8.4.8.2.3. This is a mapping from eight symbols to four symbols. For 4 transmit antennas using Matrix C, Encoding follows the coding scheme for code C in 8.4.8.2.3. This is a mapping from four symbols to one symbol.

1 *Insert new subclause 6.3.2.3.63:*
2

3 **6.3.2.3.63 MR_NBR-INFO message**
4
5

6 The MR_NBR-INFO shall be transmitted by the MR-BS to an RS. The message shall be transmitted on the
7 primary management CID. The message format for the MR_NBR-INFO message shall be in accordance with
8 Table 3.
9
10
11

| Syntax | Size | Notes |
|----------------------------------|---------|---|
| MR_NBR-INFO Message format(){ | - | - |
| Management Message Type = TBD | 8 bits | - |
| Action Type bitmap | 4 bits | Bit [0]: if set to 1, information about all the neighboring stations is present Bit [1]: if set to 1, the neighbors listed here should be appended to the existing neighbor list. Bit [2]: if set to 1, neighbors listed here should be deleted from the existing neighbor list. Bit [3]: if set to 1, information about neighbors listed here should be updated as indicated. |
| if(Action Type bitmap [0] == 1){ | - | - |
| Skip-optional-files bitmap | 8 bits | Bit [0]: if set to 1, omit Operator ID field. Bit [1]: if set to 1, omit NBR BS ID field. Bit [2]: if set to 1, omit HO process optimization field. Bit [3]: if set to 1, omit QoS related fields. Bit [4]–[7]: Reserved. |
| if (Skip-optional-fields-[0]=0){ | | |
| Operational IE | 24 bits | Unique ID assigned to the operator |
| } | - | - |
| Fragmentation Index | 4 bits | Indicates the current fragmentation index |
| Total Fragmentation | 4 bits | Indicates the total number of fragmentations. |
| N_Neighbors | 8 bits | Number of neighbors for this RS |
| for(j=0; j<N_NEIGHBORS;j++){ | - | - |
| Length | 8 bits | Length of message information within the iteration of N_NEIGHBOR in bytes. |
| PHY Profile ID | 8 bits | Aggregated IDs of Co-located FA Indicator, FA Configuration Indicator, FFT size, Bandwidth, Operation Mode of the starting subchannelization of a frame and Channel Number. |
| if(FA Index Indicator == 1){ | | |
| FA Index | 8 bits | This field, Frequency Assignment Index, is present only the FA Index Indicator in PHY Profile ID is set. Otherwise, the neighbor Station has the same FA Index or the center frequency is indicated using the TLV encoded information. |
| } | | |

1
2
3
4
5
6
7
8
9
10
11
12
13
14
15
16
17
18
19
20
21
22
23
24
25
26
27
28
29
30
31
32
33
34
35
36
37
38
39
40
41
42
43
44
45
46
47
48
49
50
51
52
53
54
55
56
57
58
59

| | | |
|---------------------------------|---------|---|
| if(Station EIRP Indicator ==1){ | | |
| Station EIRP | 8 bits | Signed Integer from –128 to 127 in unit of dBm This field is present only if the Station EIRP indicator is set in PHY Profile ID. Otherwise, the Station has the same EIRP as the serving Station. |
| } | - | - |
| if(Skip-optional-fields[1]==0){ | - | - |
| Neighbor BSID | 24 bits | This is an optional field for OFDMA PHY and it is omitted or skipped if Skip optional fields Flag = 1. |
| } | - | - |
| Preamble Index/Subchannel Index | 8 bits | This parameter defines the OFDMA PHY specific preamble |
| if(Skip-optional-field[2]==0){ | - | - |
| HO Process Optimization | 8 bits | HO Process Optimization is provided as part of this message is indicative only. HO process requirements may change at time of actual HO. For each Bit location, a value of ‘0’ indicates the associated reentry management messages shall be required, a value of ‘1’ indicates the reentry management message may be omitted. Regardless of the HO Process Optimization TLV settings, the target Station may send unsolicited SBC-RSP and/ or REGRSP management messages: Bit #0: Omit SBC-REQ/RSP management messages during reentry processing Bit #1: Omit PKM Authentication phase except TEK phase during current re-entry processing Bit #2: Omit PKM TEK creation phase during re-entry processing Bit #3: Omit REG-REQ/RSP management during current re-entry processing Bit #4: Omit Network Address Acquisition management messages during current re-entry processing Bit #5: Omit Time of Day Acquisition management messages during current reentry processing Bit #6: Omit TFTP management messages during current re-entry processing Bit #7: Full service and operational state transfer or sharing between serving station and target station (ARQ, timers, counters, MAC state machines, etc...) |
| } | - | - |
| if(Skip-optional-field[3]==0){ | - | - |

| | | | |
|----|----------------------------------|-----------|---|
| 1 | Scheduling Service Supported | 8 bits | Bitmap to indicate if Station supports a particular scheduling service. 1 indicates support, 0 indicates not support: Bit #0: Unsolicited Grant Service (UGS) Bit #1: Real-time Polling Service (rtPS) Bit #2: Non-real-time Polling Service (nrtPS) Bit #3: Best Effort Bit #4: Extended real-time Polling Service (ertPS) If the value of bit 0 through bit 4 is 0b00000, it indicates no information on service available. Bits #5-7: Reserved; shall be set to zero. |
| 2 | | | |
| 3 | | | |
| 4 | | | |
| 5 | | | |
| 6 | | | |
| 7 | | | |
| 8 | | | |
| 9 | | | |
| 10 | | | |
| 11 | | | |
| 12 | | | |
| 13 | | | |
| 14 | } | - | - |
| 15 | | | |
| 16 | DCD Configuration Change Count | 4 bits | This represents the 4 LSBs of the Neighbor Station current DCD configuration change count. |
| 17 | | | |
| 18 | | | |
| 19 | UCD Configuration Change Count | 4 bits | This represents the 4 LSBs of the Neighbor Station current DCD configuration change count. |
| 20 | | | |
| 21 | | | |
| 22 | | | |
| 23 | TLV Encoded Neighbor information | variables | TLV specific |
| 24 | | | |
| 25 | } | - | - |
| 26 | | | |
| 27 | } | | |
| 28 | | | |
| 29 | if(Action Type bitmap[1]==1){ | - | - |
| 30 | | | |
| 31 | Skip-optional-files bitmap | 8 bits | Bit [0]: if set to 1, omit Operator ID field. Bit [1]: if set to 1, omit NBR BS ID field. Bit [2]: if set to 1, omit HO process optimization field. Bit [3]: if set to 1, omit QoS related fields. Bit [4]-[7]: Reserved. |
| 32 | | | |
| 33 | | | |
| 34 | | | |
| 35 | | | |
| 36 | | | |
| 37 | if(Skip-optional-fields[0]=0){ | - | - |
| 38 | | | |
| 39 | Operator ID | 24 bits | Unique ID assigned to the operator. |
| 40 | | | |
| 41 | } | - | - |
| 42 | | | |
| 43 | Fragmentation Index | 4 bits | Indicates the current fragmentation index. |
| 44 | Total Fragmentation | 4 bits | Indicates the total number of fragmentations. |
| 45 | New N_NEIGHBORS | 8 bits | Number of new neighbors for this RS |
| 46 | | | |
| 47 | for(j=0;j<New N_NEIGHBORS;j++){ | - | - |
| 48 | | | |
| 49 | Length | 8 bits | Length of message information within the iteration of New_N_NEIGHBOR in bytes. |
| 50 | | | |
| 51 | PHY Profile ID | 8 bits | Aggregated IDs of Co-located FA Indicator, FA Configuration Indicator, FFT size, Bandwidth, Operation Mode of the starting subchannelization of a frame and Channel Number. |
| 52 | | | |
| 53 | | | |
| 54 | | | |
| 55 | if(FA Index Indicator==1){ | - | - |
| 56 | | | |
| 57 | | | |
| 58 | | | |
| 59 | | | |

1
2
3
4
5
6
7
8
9
10
11
12
13
14
15
16
17
18
19
20
21
22
23
24
25
26
27
28
29
30
31
32
33
34
35
36
37
38
39
40
41
42
43
44
45
46
47
48
49
50
51
52
53
54
55
56
57
58
59

| | | |
|---------------------------------|---------|--|
| FA Index | 8 bits | This field, Frequency Assignment Index, is present only the FA Index Indicator in PHY Profile ID is set. Otherwise, the neighbor Station has the same FA Index or the center frequency is indicated using the TLV encoded information. |
| } | - | - |
| if(Station EIRP Indicator ==1){ | - | - |
| Station EIRP | 8 bits | Signed Integer from -128 to 127 in unit of dBm This field is present only if the Station EIRP indicator is set in PHY Profile ID. Otherwise, the Station has the same EIRP as the serving Station. |
| } | - | - |
| if(Skip-optional-field[1]=0){ | - | - |
| Neighbor BSID | 24 bits | This is an optional field for OFDMA PHY and it is omitted or skipped if Skip optional fields Flag = 1. |
| } | - | - |
| Preamble Index/Subchannel Index | 8 bits | This parameter defines the OFDMA PHY specific preamble |
| if(Skip-optional-field[2]=0){ | - | - |

| | | | |
|---|----------------------------------|-----------|---|
| 1 2 3 4 5 6 7 8 9 10 11 12 13 14 15 16 17 18 19 20 21 22 23 24 25 26 27 28 29 | HO Process Optimization | 8 bits | HO Process Optimization is provided as part of this message is indicative only. HO process requirements may change at time of actual HO. For each Bit location, a value of '0' indicates the associated reentry management messages shall be required, a value of '1' indicates the reentry management message may be omitted. Regardless of the HO Process Optimization TLV settings, the target Station may send unsolicited SBC-RSP and/ or REGRSP management messages: Bit #0: Omit SBC-REQ/RSP management messages during reentry processing Bit #1: Omit PKM Authentication phase except TEK phase during current re-entry processing Bit #2: Omit PKM TEK creation phase during re-entry processing Bit #3: Omit REG-REQ/RSP management during current re-entry processing Bit #4: Omit Network Address Acquisition management messages during current re-entry processing Bit #5: Omit Time of Day Acquisition management messages during current reentry processing Bit #6: Omit TFTP management messages during current re-entry processing Bit #7: Full service and operational state transfer or sharing between serving station and target station (ARQ, timers, counters, MAC state machines, etc...) |
| 30 | } | - | - |
| 31 | if(Skip-optional-field[3]=0){ | - | - |
| 32 33 34 35 36 37 38 39 40 41 42 43 44 | Scheduling Service Supported | 8 bits | Bitmap to indicate if Station supports a particular scheduling service. 1 indicates support, 0 indicates not support: Bit #0: Unsolicited Grant Service (UGS) Bit #1: Real-time Polling Service (rtPS) Bit #2: Non-real-time Polling Service (nrtPS) Bit #3: Best Effort Bit #4: Extended real-time Polling Service (ertPS) If the value of bit 0 through bit 4 is 0b00000, it indicates no information on service available. Bits #5-7: Reserved; shall be set to zero. |
| 45 46 | } | - | - |
| 47 48 49 | DCD Configuration Change Count | 4 bits | This represents the 4 LSBs of the Neighbor Station current DCD configuration change count. |
| 50 51 52 | UCD Configuration Change Count | 4 bits | This represents the 4 LSBs of the Neighbor Station current DCD configuration change count. |
| 53 | TLV Encoded Neighbor information | variables | TLV specific |
| 54 55 | } | - | - |
| 56 57 58 59 | } | | |

1 The following TLV parameters can be included:
2

3 **DCD Configuration Change Count**

4 Represents the 4 LSBs of the Neighbor access station current DCD configuration change count.
5

6 **UCD Configuration Change Count**

7 Represents the 4 LSBs of the Neighbor access station current UCD configuration change count.
8
9

10
11
12 For each advertised Neighbor access station, the following TLV parameters may be included:
13

14 **Mobility Feature Supported**

15 Same as in 11.7.14.1.
16
17

18
19
20 When Mobility Feature Supported bit indicate support for idle mode, following TLV parameters may be in-
21 cluded :

22 **DCD_settings**

23 The DCD_settings is a TLV value that encapsulates a DCD message (excluding the generic MAC
24 header and CRC) that may be transmitted in the advertised access station downlink channel. This
25 information is intended to enable fast synchronization of the MS with the advertised access sta-
26 tion downlink. The DCD settings fields shall contain only neighbor's DCD TLV values that are
27 different from the current access station corresponding values. For values that are not included,
28 the MS shall assume they are identical to the corresponding values of the current access station.
29 The duplicate TLV encoding parameters within a Neighbor access station shall not be included in
30 DCD setting.
31
32

33 **UCD_settings**

34 The UCD_settings is a TLV value that encapsulates a UCD message (excluding the generic MAC
35 header and CRC) that may be transmitted in the advertised access station downlink channel. This
36 information is intended to enable fast synchronization of the MS with the advertised access sta-
37 tion uplink. The UCD settings fields shall contain only neighbor's UCD TLV values that are dif-
38 ferent from the current access station's corresponding values. For values that are not included,
39 the MS shall assume they are identical to the current access station's corresponding values. The
40 duplicate TLV encoding within a Neighbor access station shall not be included in UCD setting.
41
42
43

44 **PHY Mode ID (see 11.18.1)**

45 a 16-bit value that specifies the PHY parameters, including channel bandwidth, FFT size, cyclic
46 prefix, and frame duration.
47
48
49

50
51 *Insert new subclause 6.3.2.3.64:*
52

53 **6.3.2.3.64 MR_Code-REP message**

54
55
56 This message is used by an RS to notify the MR-BS that it has successfully received CDMA ranging codes.
57

58
59 This message is transmitted using the RS's basic CID. See 11.X for MR_CODE-REP TLV

Table xx—MR Code Report(MR_CODE-REP) message Format

| Syntax | Size | Note |
|------------------------------|----------|------|
| MR_Code_Report_format() { | | |
| Management Message Type = xx | 8 bits | TBA |
| MR_CODE-REP TLVs | Variable | |
| } | | |

6.3.3 Construction and transmission of MAC PDUs

6.3.3.2 Concatenation

Insert the following after the first paragraph:

In MR networks, multiple MAC PDUs may be concatenated into a single transmission in either the uplink or downlink directions. Downlink MAC PDUs on relay links and downlink MAC PDUs on access links shall not be concatenated into the same burst.

Insert new subclause 6.3.3.8:

6.3.3.8 MMR construction and transmission of MAC PDUs

MPDUs from connections that are not assigned to traverse a tunnel are constructed according to the sections 6.3.3.1 - 6.3.3.7 RSs forward MPDUs from connections that are not assigned to a tunnel based on the CID of the connection.

Insert new subclause 6.3.3.8.1:

6.3.3.8.1 Transmission using Tunnels

All MPDUs from a connection that is assigned to traverse a tunnel must be transmitted through that tunnel. There are two modes for constructing and forwarding MPDUs from connections that traverse a tunnel. In the first mode, called Tunnel Packet Mode, MPDUs that traverse a tunnel are encapsulated in an MPDU header which carries the T-CID for MT-CID of the tunnel. This header along with the encapsulated MPDUs is called a tunnel packet. Multiple MPDUs from connections that traverse the tunnel can be concatenated into a tunnel packet for transmission. The station at the ingress of the tunnel is responsible for encapsulating the MPDUs into tunnel packets, and the station at the egress of the tunnel is responsible for removing the tunnel header and forwarding the encapsulated MPDUs based on their individual CIDs. Stations through which a tunnel traverses may forward the tunnel packets based on the TCID or MT-CID in the tunnel header. When tunnel packets are transmitted in tunnel packet mode, the T-CID or MT-CID may appear in the map IE that describes the allocation in which the burst is transmitted. Alternately, the T-CID or MT-CID can be omitted from map IEs and the RSs can determine the T-CID or MT-CID of a packet by parsing the tunnel header. When a tunnel traverses more than one RS, separate IEs may be used to describe the bursts allocated to this

1 tunnel at different RSs. In this mode, multiple tunnel packets, potentially from different tunnels traversing
 2 an RS can be concatenated into a single PHY burst.
 3

4 In the second mode, called Tunnel Burst Mode, MPDUs transmitted through a tunnel are concatenated
 5 together into PHY bursts and transmitted without appending a tunnel header, in order to save bandwidth and
 6 reduce the MPDU processing time. In this mode, the T-CID or MT-CID of the tunnel is specified in the map
 7 IE to identify the tunnel on which the PHY burst is transmitted. In this mode, all MPDUs in a PHY burst
 8 must be from connections that traverse the tunnel. The station at the ingress of the tunnel that operated in
 9 tunnel burst mode is responsible for concatenating the MPDUs into from individual tunnels into PHY bursts,
 10 and the station at the egress of the tunnel is responsible for forwarding the concatenated MPDUs based on
 11 their individual CIDs. Stations through which a tunnel traverses may forward the tunnel packets based on
 12 the T-CID or MT-CID in the map IE.
 13
 14

15 *Insert new subclause 6.3.3.8.2:*
 16

17 **6.3.3.8.2 Transmission using station CID**

18 The construction of MPDUs is the same as without relay. The forwarding of MPDUs by each RS is per-
 19 formed based on the CID. An RS is informed apriori about the next hop station during SF setup for a station
 20 CID. The inclusion of CID in DLMAP is optional as it is without relay.
 21
 22
 23

24 **6.3.4 ARQ mechanism**

25 **6.3.4.6 ARQ operation**

26
 27
 28
 29
 30 *Insert new subclause 6.3.4.6.4:*
 31

32 **6.3.4.6.4 ARQ modifications for relaying**

33 **6.3.5 Scheduling services**

34 **6.3.6 Bandwidth allocation and request mechanisms**

35
 36
 37
 38
 39
 40
 41 *Insert new subclause 6.3.6.7:*
 42

43 **6.3.6.7 Relay ~~support for scheduling~~ bandwidth request and allocation mechanisms**

44
 45 In all bandwidth request and allocation mechanisms, the SS shall use the same CDMA bandwidth request
 46 procedure as specified in 6.3.6.5.
 47

48
 49 *Insert new subclause 6.3.6.7.1:*
 50

51 **6.3.6.7.1 Distributed ~~scheduling~~ bandwidth request and allocation**

52
 53 In relay systems with distributed bandwidth request and allocation, each MR-BS and RS individually deter-
 54 mines the bandwidth allocations on the links it controls (i.e. downlinks to and uplinks from its immediate
 55 downstream stations) and creates it own MAPs reflecting these decisions.
 56

57
 58 Bandwidth request and allocation procedures on the access link (i.e. between the SS and its access RS or
 59 MR-BS) are the same as those outlined in 6.3.6.1-6.3.6.3 and 6.3.6.5.

1 The following subclauses specify bandwidth request and allocation procedures for the relay link (i.e.
2 between an RS and its upstream RS or MR-BS) in relay systems with distributed control. <Section note:
3 additional BW request and allocation mechanisms may be defined for the relay link to improve its BW utili-
4 zation. This is TBD.>
5

6 *Insert new subclause 6.3.6.7.1.1:*
7

8 **6.3.6.7.1.1 Bandwidth requests** 9

10 The bandwidth request from an RS may come as a stand-alone bandwidth request header or piggybacked on
11 other MAC PDUs. If it is a stand-alone bandwidth request header, it may come as a response to a poll (see
12 6.3.6.7.1.1.3) or as a result of a contention-based CDMA bandwidth request process (see 6.3.6.7.1.1.4).
13 Because the uplink profile can change, all requests shall be made in terms of the number of bytes needed to
14 carry the MAC header and payload, but not the PHY overhead. The bandwidth request header may be trans-
15 mitted during any relay uplink allocation, except during initial ranging.
16
17

18 An RS may combine the bandwidth requests that arrive from downstream stations during a given period of
19 time along with the bandwidth needs of packets in queue into one BW request header per QoS class. When
20 resources are available, the upstream station will allocate bandwidth using the RS's Basic CID. The
21 upstream station shall expect to receive concatenated (see Section 6.3.3.2) MAC PDUs with CIDs of trans-
22 port connections from stations further down the tree.
23

24 In addition, the RS can transmit an aggregate or incremental bandwidth request. When the upstream station
25 receives an incremental bandwidth request, it shall add the quantity of bandwidth requested to its current
26 perception of the bandwidth needs of the connection. When the upstream station receives an aggregate band-
27 width request, it shall replace its perception of the bandwidth needs of the connection with the quantity of
28 bandwidth requested. The Type field in the bandwidth request header indicates whether the request is incre-
29 mental or aggregate. Since piggybacked bandwidth request do not have a type field, they shall always be
30 incremental.
31
32

33 The RS may transmit a BW request header soon after it receives a BW request header from one of its down-
34 stream stations (timed to yield an uplink allocation sequential to the arrival of those packets) instead of wait-
35 ing for the actual packets to arrive in order to reduce delay in relaying traffic (see Figure x.1). <Section
36
37
38
39
40
41
42
43
44
45
46
47
48
49
50
51
52
53
54
55
56
57
58
59

1 note: the BW request headers defined for the relay link may be different from those defined for the access
 2 link to improve its BW utilization. This is TBD.
 3
 4
 5
 6
 7

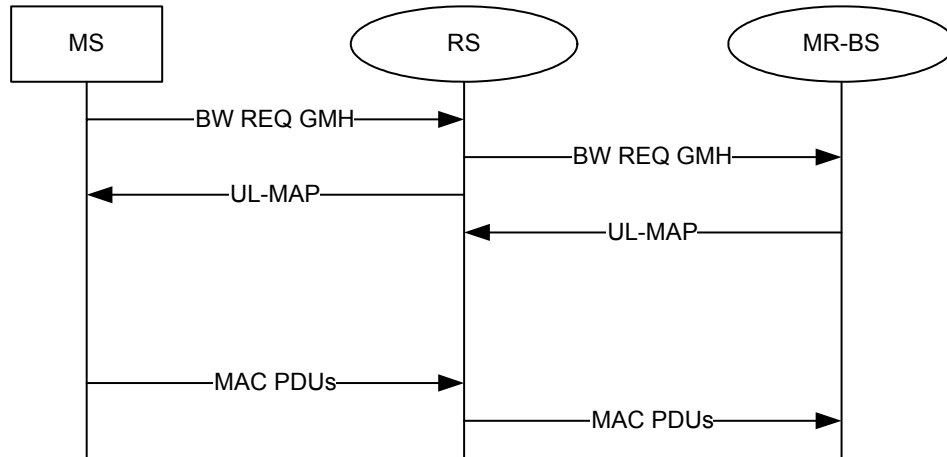

26 **Figure X.01—Reducing latency in relaying traffic by transmitting BW req. header on R-UL**
 27 **before packets arrive**

28
 29
 30 **Insert new subclause 6.3.6.7.1.2:**

31 **6.3.6.7.1.2 Grants**

32
 33
 34
 35 RS bandwidth requests may reference specific connections, while each bandwidth grant an RS receives from
 36 its upstream station is addressed to the RS identifier. <Section note: identifier is TBD.>. The RS can sched-
 37 ule any MAC PDU on the bandwidth allocations it receives from its upstream station.
 38

39 **Insert new subclause 6.3.6.7.1.3:**

40 **6.3.6.7.1.3 Polling**

41
 42
 43 MR-BSs and RSs can allocate bandwidth to a downstream RS or a group of downstream RSs for the purpose
 44 of transmitting a bandwidth request header. This polling process on the relay link is the same as that defined
 45 for the access link in 6.3.6.3.
 46
 47
 48
 49
 50
 51
 52
 53
 54
 55
 56
 57
 58
 59

1 If the RS is regularly polled, it can transmit a bandwidth request header on the relay uplink as soon as it
 2 senses the lack of bandwidth for its subordinate MSs and RSs, thereby reducing relaying delay (see Figure
 3 x.2).
 4
 5
 6
 7
 8

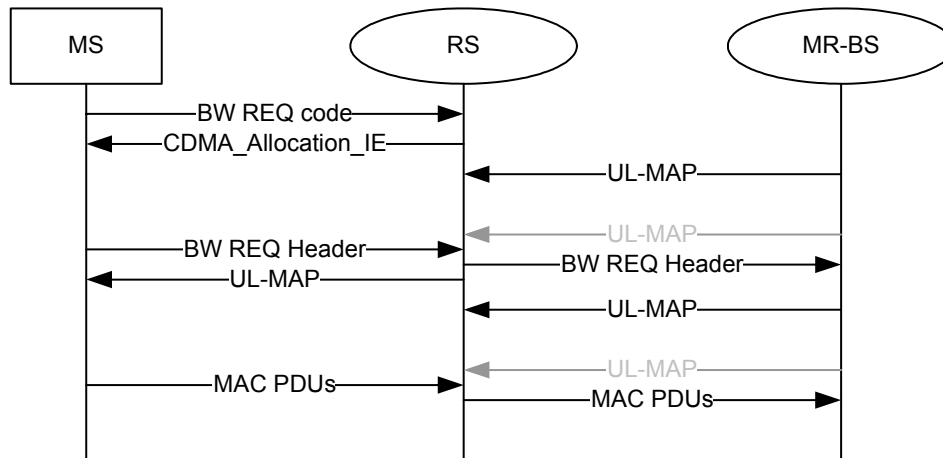

25
26 **Figure x.02—Reducing latency in relaying traffic via RS polling**

27
28
29 **Insert new subclause 6.3.6.7.1.4:**

30 **6.3.6.7.1.4 Contention-based CDMA bandwidth requests**

31
32
33
34 The contention-based CDMA bandwidth request process on the relay link is the same as that on the access
 35 link detailed in 6.3.6.5. The set of ranging codes used for bandwidth request on the relay link is the same as
 36 that used for the access link.

37
38 Upon needing bandwidth, the RS shall select a ranging code with equal probability from the code subset
 39 allocated for bandwidth requests. This ranging code shall be modulated onto the ranging subchannels and
 40 transmitted during the appropriate relay uplink allocation.
 41

42 Upon detection of the ranging code, the RS's upstream station shall provide a relay uplink allocation using a
 43 CDMA_Allocation_IE specifying the transmit region and ranging code used by the RS. Once the RS deter-
 44 mines it has been given an allocation by matching the transmit region and code it used against those speci-
 45 fied by the CDMA_Allocation_IE, it shall use the allocation to transmit a bandwidth request header and/or
 46 data. If the upstream station does not issue a relay uplink allocation or if the bandwidth request header does
 47 not result in a bandwidth allocation, the RS shall assume a collision took place and follow the contention
 48 resolution specified in 6.3.8.
 49
 50
 51
 52
 53
 54
 55
 56
 57
 58
 59

1
2
3
4
5
6
7
8
9
10
11
12
13
14
15
16
17
18
19
20
21
22
23
24
25
26
27
28
29
30
31
32
33
34
35
36
37
38
39
40
41
42
43
44
45
46
47
48
49
50
51
52
53
54
55
56
57
58
59

The RS may reduce the latency of relaying traffic by sending a bandwidth request CDMA ranging code as soon as it receives one from a downstream station instead of waiting for the actual packets to arrive (see Figure x.3).

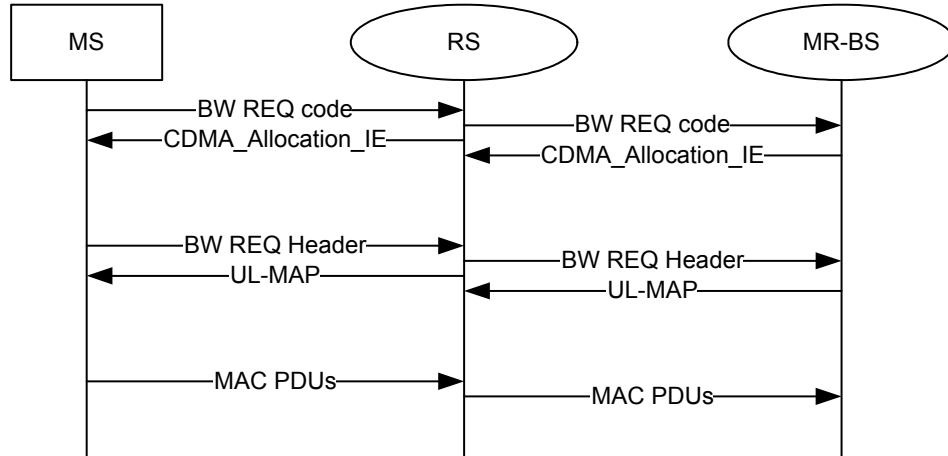

Figure x. 03—Reducing latency in relaying traffic by early transmission of BW request ranging code on the R-UL

Insert new subclause 6.3.6.7.2:

6.3.6.7.2 Centralized ~~scheduling~~ bandwidth request and allocation

In systems with centralized bandwidth allocation, the MR-BS shall determine the bandwidth allocations for all links (access and relay) in its MR-cell. Thus, before a station can transmit a packet to the MR-BS, that station’s bandwidth request must first reach the MR-BS, which then creates bandwidth allocations on the links along the path from the station to the MR-BS.

Insert new subclause 6.3.6.7.2.1:

6.3.6.7.2.1 Contention-based CDMA Bandwidth Requests for Relay

The MR-BS shall assign unique RS CDMA ranging codes to each RS in its MR-cell in order to reduce the overhead and latency of various ranging processes in relay networks with centralized control (see subclause 6.3.10.3.x). RS CDMA ranging codes are assigned to an RS during its initial ranging process by sending an RS_CDMA_Codes TLV in the RNG-RSP.

A set of these RS CDMA ranging codes may be reserved for the purpose of informing the MR-BS that an SS attached to the originating RS is requesting to forward a BW request header to the MR-BS. When the MR-BS receives such a code, it shall create BW allocations on the access link and the relay links along the path to the MR-BS for the purpose of forwarding a BW request header from the SS to the MR-BS. This requires that the MR-BS not only know the path from the RS but also the processing time at each RS in the MR-cell.

Thus, when an RS receives a BW request CDMA ranging code from one of its SSs, it shall send the appropriate RS CDMA ranging code toward the MR-BS indicating that one of its SSs is requesting to forward a

1 BW request header to the MR-BS. Each intermediate RS along the path to the MR-BS relays this code in the
2 uplink direction. Upon receiving this code, the MR-BS shall respond by creating the appropriate downlink
3 and uplink allocations.
4

5 Another set of RS CDMA ranging codes may be reserved for the purpose of informing the MR-BS that the
6 originating RS is requesting to forward a BW request header to the MR-BS. Although RSs do not create data
7 traffic, they may need to request bandwidth for management messages or for queued SS data if previous BW
8 allocations did not suffice due to unsuccessful transmissions, changes in modulation/coding rate, etc. The
9 MRBS responds to this type of code in a manner similar to the one described above except that there is not
10 access uplink allocation.
11

12
13 *Insert new subclause 6.3.6.7.2.2:*

14 **6.3.6.7.2.2 Continuous bandwidth allocation mechanism**

15
16
17 MR-BSs and RSs shall support the continuous bandwidth allocation mechanism specified in this subclause.
18 When an MR-BS allocates bandwidth to forward a packet to/from a given station, it shall allocate bandwidth
19 on all links (relay and access) that make up the path to/from that station taking into account the processing
20 delay at each RS along the path as well as the multi-hop frame structure.
21

22
23 To create this continuous forwarding of a packet, the MR-BS shall allocate bandwidth on consecutive links
24 along a path by creating an allocation for the second link at the first opportunity after the allocation of the
25 first link plus the intermediate station's processing time. Each RS's uplink processing delay is notified to the
26 MR-BS using the SBC-REQ message during the RS's network entry process.
27

28 **6.3.7 MAC support of PHY**

29
30
31 ~~Insert the following text at the end of the subclause 6.3.7.2:~~

32
33
34 ~~For the case where MR-BS supports two hop relay, the DL and UL subframes shall include at least one~~
35 ~~access zone and may include one or more relay zone to enable RS operating in either transmit or receive~~
36 ~~mode. The related frame structure is defined in the OFDMA PHY specific section.~~
37

38
39 *Change subclause 6.3.7.3 as indicated:*

40 **6.3.7.3 DL-MAP**

41
42
43 The DL-MAP message defines the usage of the downlink intervals on the access links for a burst mode
44 PHY.
45

46
47
48 *Change subclause 6.3.7.4 as indicated:*

49 **6.3.7.4 UL-MAP**

50
51
52 The UL-MAP message defines the uplink usage on the access link in terms of the offset of the burst relative
53 to the Allocation Start Time (units PHY-specific)
54

55 **6.3.7.7 Optional MAC support of the PHY for relaying**

56
57
58
59 *Insert new subclause 6.3.7.7:*

6.3.7.7 Optional MAC support of the PHY for relaying

6.3.8 Contention resolution

6.3.9 Network entry and initialization

Insert new subclause 6.3.9.16:

6.3.9.16 Support for network entry and initialization in relay mode

Insert new subclause 6.3.9.16.1:

6.3.9.16.1 MS network entry procedures in transparent RS systems

In network entry procedure in transparent RS systems, MS scans for downlink channel and establish synchronization with the MR-BS, then obtains transmit parameters from UCD message as described in 6.3.9.1 through 6.3.9.4.

The initial ranging process shall begin by sending initial-ranging CDMA codes on the UL allocation dedicated for that purpose (for more details see 6.3.10.3). The RS shall monitor ranging channel assigned by the MR-BS.

The code may be received by the MR-BS and some RSs near the MS. RSs receiving the code with sufficient signal quality shall transmit a RNG-REQ to the MR-BS with the RS basic CID. The RNG-REQ message contains ranging status, code attributes and adjustment information such as frequency, timing and transmission power. When a RS receives multiple codes in a frame, the RS sends a RNG-REQ message which contains information of multiple codes which are received with sufficient signal quality.

When the MR-BS receives ranging code, it shall wait for RNG-REQ with the same ranging code from its subordinate RSs for T48 timer. Once T48 timer expired, the MR-BS compares measured signal information at each station to decide the most appropriate path to communicate with the code originating MS, according to channel measurement information. Algorithms to select a path are out of scope of this document.

When the ranging status at the selected path is continue, the MR-BS transmits a RNG-RSP to the MS directly with initial ranging CID. The RNG-RSP shall contain adjustment information measured at the RS on the selected path. If the ranging code has been successfully received at the access RS on the selected path and the MR-BS decides to apply uplink and downlink relaying to the MS, the RS receives and relays a RNG-REQ message transmitted on a burst specified with CDMA_Allocation-IE in UL-MAP after decoding the UL-MAP or optionally R-MAP in the same frame. The MAP messages and IEs are defined in 8.4.5. If the direct communication is selected, the MR-BS follows sequence described in 6.3.10.3.

Once the RS receives a RNG-REQ containing MS MAC address with initial ranging CID, it forwards the message to the MR-BS with the RS basic CID, so that the MR-BS can identify the RS with which the MS connects.

Receiving the RNG-REQ, the MR-BS assigns basic and primary CIDs to the MS and sends the RNG-RSP, which contains just assigned CIDs of MS, to the MS directly with the initial ranging CID.

After assigning the basic and primary CID to the MS, the MS and the MR-BS continue network entry process as described in the 6.3.9.7 through 6.3.9.13 using the MS's management CIDs. The RS on the selected path shall relay messages between them. The RS may monitor management messages and derive some information for some purpose which is out of scope of this document.

The message sequences chart (Figure xxx) and flow charts (Figure xxx, Figure xxx, and Figure xxx) on the following pages define the ranging and adjustment process that shall be followed by compliant RSs and MMR-BSSs. For CDMA ranging process between RS and MS, these details can be found in 6.3.10.3.

Optionally, the MS network entry process in transparent RS system will proceed with relaying of messages and data on uplink only, while relying on the direct MR-BS to MS transmissions on the downlink. The message sequence chart for this process is the same as the one of DL/UL relaying described in Table xxx.

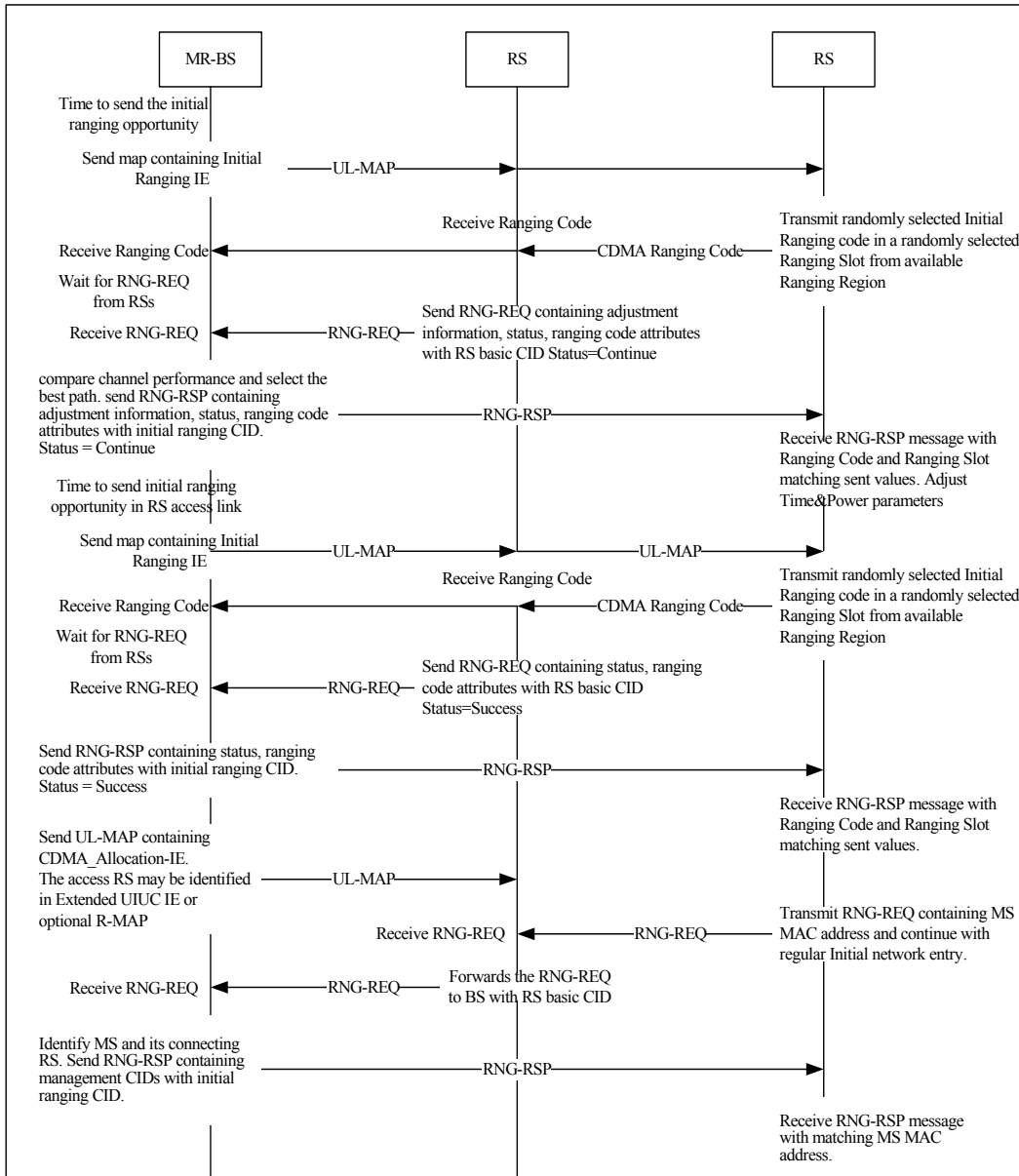

Figure XXX —Ranging and automatic adjustments procedure in MR mode

1
2
3
4
5
6
7
8
9
10
11
12
13
14
15
16
17
18
19
20
21
22
23
24
25
26
27
28
29
30
31
32
33
34
35
36
37
38
39
40
41
42
43
44
45
46
47
48
49
50
51
52
53
54
55
56
57
58
59

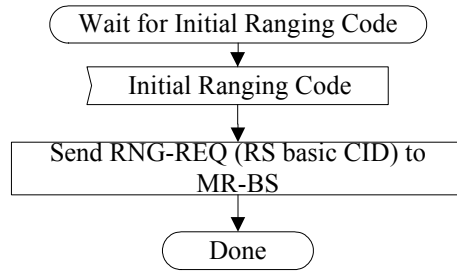

Figure XXX —MS CDMA Initial Ranging -- Access Transparent RS

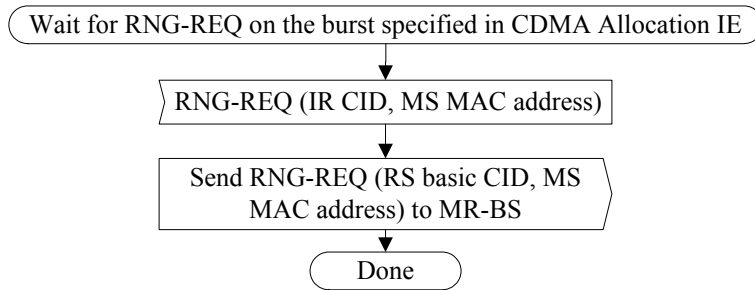

Figure XXX—MS Initial Ranging -- Access Transparent RS

1
2
3
4
5
6
7
8
9
10
11
12
13
14
15
16
17
18
19
20
21
22
23
24
25
26
27
28
29
30
31
32
33
34
35
36
37
38
39
40
41
42
43
44
45
46
47
48
49
50
51
52
53
54
55
56
57
58
59

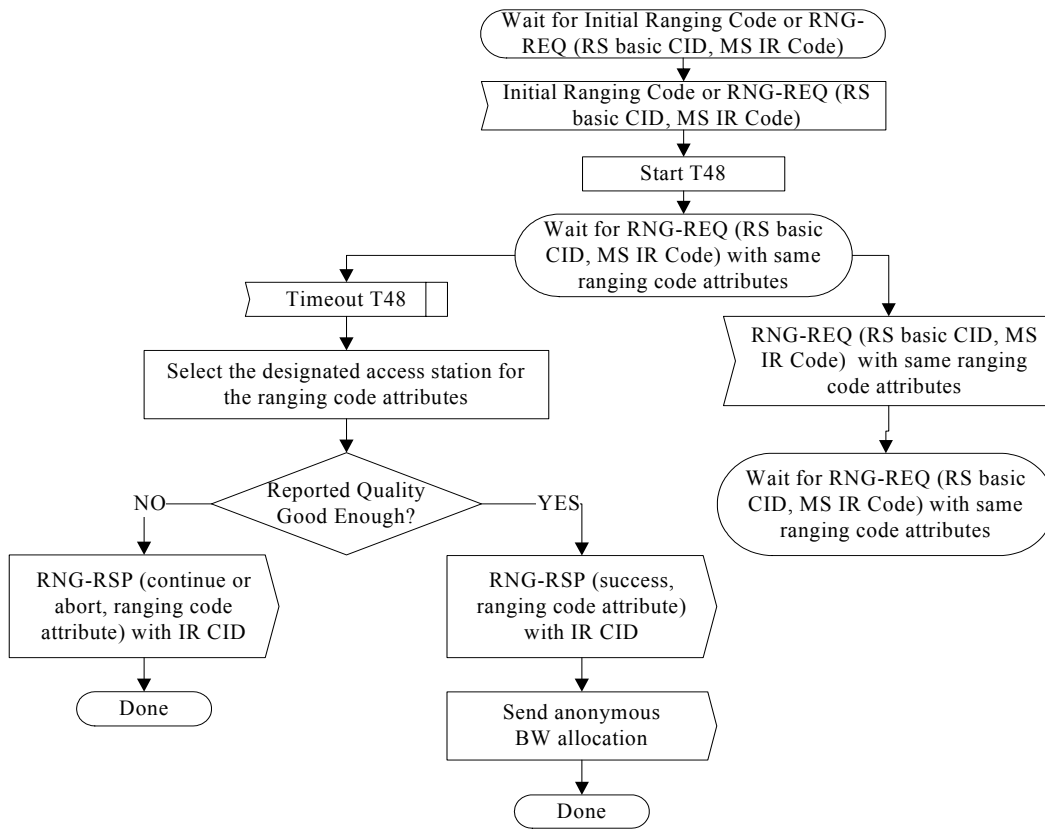
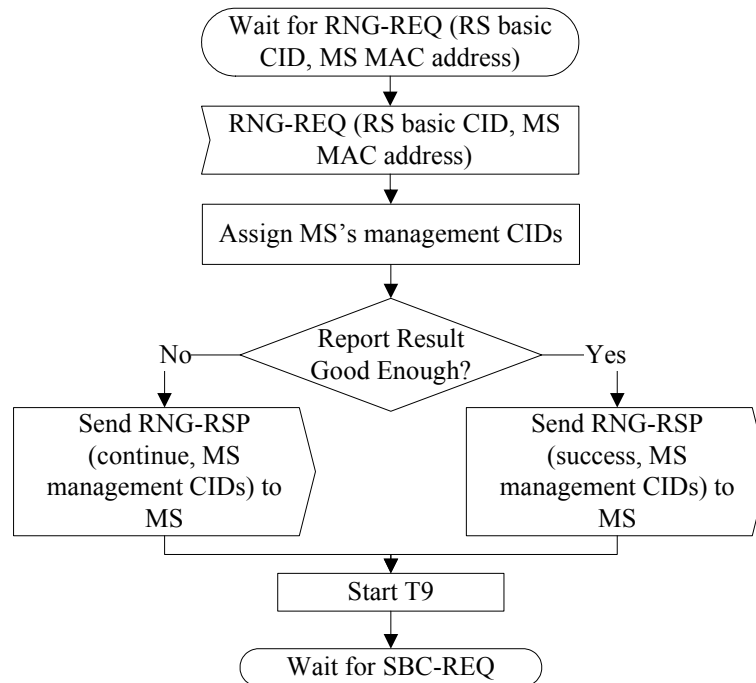

Figure XXX —MS CDMA Initial Ranging with Transparent RS -- MR-BS



26 Note: T9 is the timer between the MR-BS sending an RNG-
27 RSP to an MS and receiving an SBC-REQ from the same MS
28
29

30 **Figure <xxx>—MS Initial Ranging with Transparent RS-- MR-BS**
31
32
33
34
35

36 *Insert new subclause 6.3.9.16.2:*

37 **6.3.9.16.2 MS network entry procedures in non-transparent RS systems**

38
39
40
41 *Insert new subclause 6.3.9.16.2.1:*

42 **6.3.9.16.2.1 Non-transparent RS with Centralized scheduling**

43
44
45
46 *Insert new subclause 6.3.9.16.2.2:*

47 **6.3.9.16.2.2 Non-transparent RS with Distributed scheduling**

48
49
50
51 In MS network entry procedures to non-transparent RS systems, MS scans for downlink channel and estab-
52 lish synchronization with the non-transparent RS, then obtains transmit parameters from UCD message as
53 described in 6.3.9.1 through 6.3.9.4.
54

55
56 The initial ranging process shall begin by sending an initial-ranging CDMA codes on the UL allocation ded-
57 icated for that purpose (for more details see 6.3.10.3). RS and MS continue CDMA code transmission and
58 reception as defined in 6.3.10.3 until RS receives the CDMA code successfully unless the MS receives abort
59 status in RNG-RSP or the retry count exceeds the maximum number.

1 When the RS receives the CDMA code resulting in success status, it sends a RNG-RSP containing success
2 status to the MS. And the RS also provides bandwidth allocation to the MS with CDMA_Allocation-IE in
3 UL-MAP, so that the MS can send a RNG-REQ containing MS MAC Address with initial ranging CID.
4

5 Receiving the RNG-REQ containing the MS MAC Address, the RS relays it with the RS basic CID to MR-
6 BS.
7

8 Once the MR-BS receives the RNG-REQ containing MS MAC Address with the RS basic CID, the MR-BS
9 shall assign Basic and Primary management CIDs to the MS, and transmit a RNG-RSP containing those
10 management CIDs and MS MAC Address with the RS basic CID.
11

12 The RS receiving the RNG-RSP containing the management CIDs and MS MAC Address shall relay it to
13 the MS with the initial ranging CID.
14

15 After assigning the basic and primary management CID to a MS, the MS and MR-BS continue network
16 entry process as described in the 6.3.9.7 through 6.3.9.13 using MS's management CIDs. The RS shall relay
17 management messages between them.
18

19 Optionally, the RS may send a RNG-REQ message containing New MS Indication ID TLV with the RS's
20 basic CID to the MR-BS upon receiving the CDMA code successfully before it sends a RNG-RSP to the
21 MS. In this case, when receiving the RNG-REQ containing New MS Indication ID TLV, the MR-BS con-
22 firms whether it can accept a new MS entry request. If it can accept the request, it sends a RNG-RSP con-
23 taining success status to the RS, otherwise a RNG-RSP with abort status. When the RS receives the RNG-
24 RSP with ranging status from the MR-BS, it sends a RNG-RSP containing the same ranging status as in the
25 received RNG-RSP and the ranging code attributes with initial ranging CID. If the ranging status in the
26 RNG-RSP is success, the RS provides bandwidth allocation with CDMA_Allocation-IE in UL-MAP, so that
27 the MS can send a RNG-REQ containing MS MAC Address with initial ranging CID.
28
29

30 When the RS relays the received RNG-REQ to the MR-BS, it shall add the New MS Indication ID same as
31 the one used in the previous RNG-REQ transmitted upon successful reception of CDMA ranging code, so
32 that the MR-BS can recognize the two RNG-REQ messages containing the same New MS Indication ID are
33 used for the same MS network entry process.
34
35

36 The message sequences chart (Figure <XXX>02 and Figure <XXX>03) on the following page defines the
37 ranging and adjustment process that shall be followed by compliant RSs and MR-BSs. For CDMA ranging
38 process between RS and MS, these details can be found in 6.3.10.3.
39
40
41
42
43
44
45
46
47
48
49
50
51
52
53
54
55
56
57
58
59

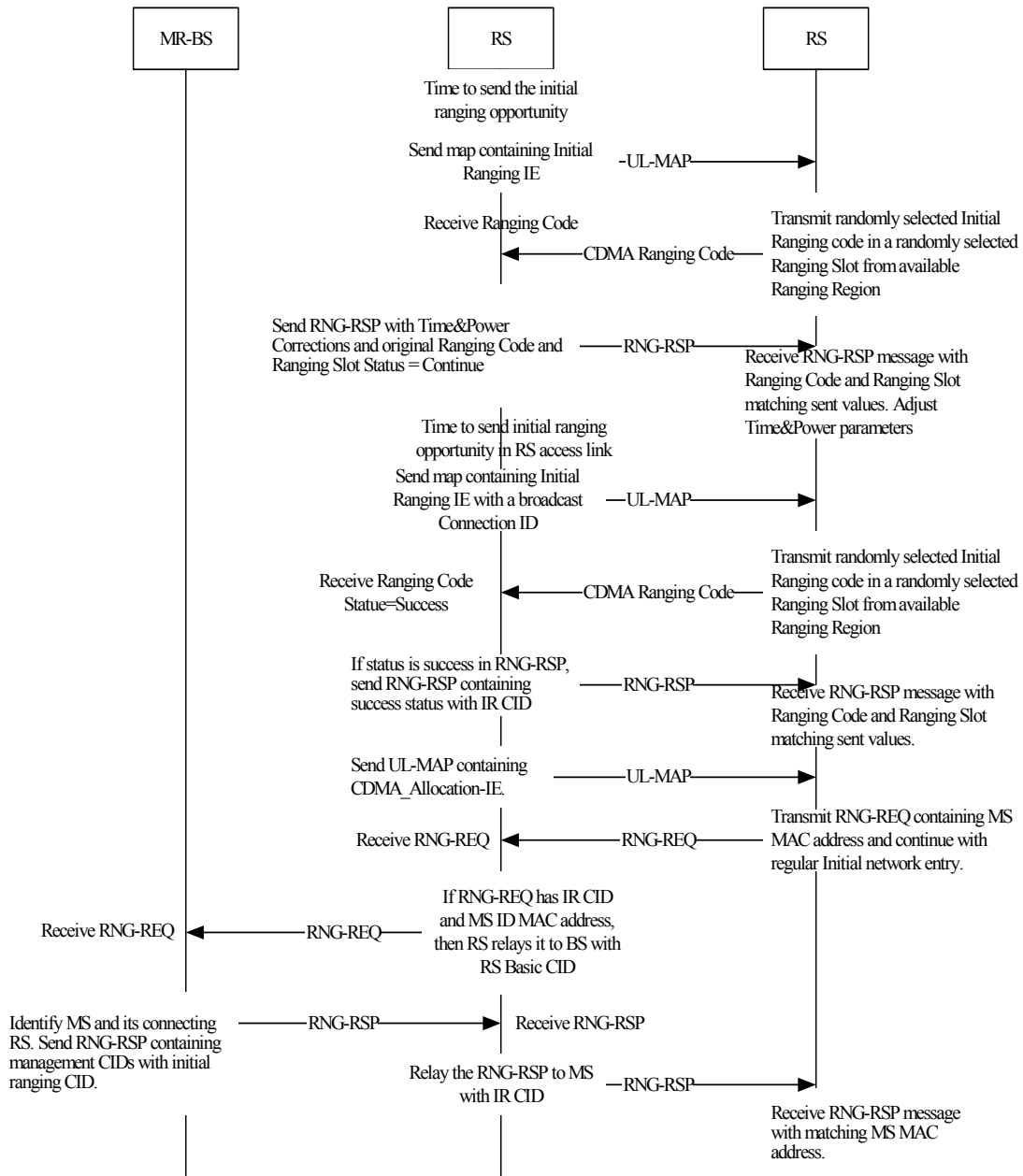

Figure <XXX>02—Ranging and automatic adjustments procedure in MR mode

1
2
3
4
5
6
7
8
9
10
11
12
13
14
15
16
17
18
19
20
21
22
23
24
25
26
27
28
29
30
31
32
33
34
35
36
37
38
39
40
41
42
43
44
45
46
47
48
49
50
51
52
53
54
55
56
57
58
59

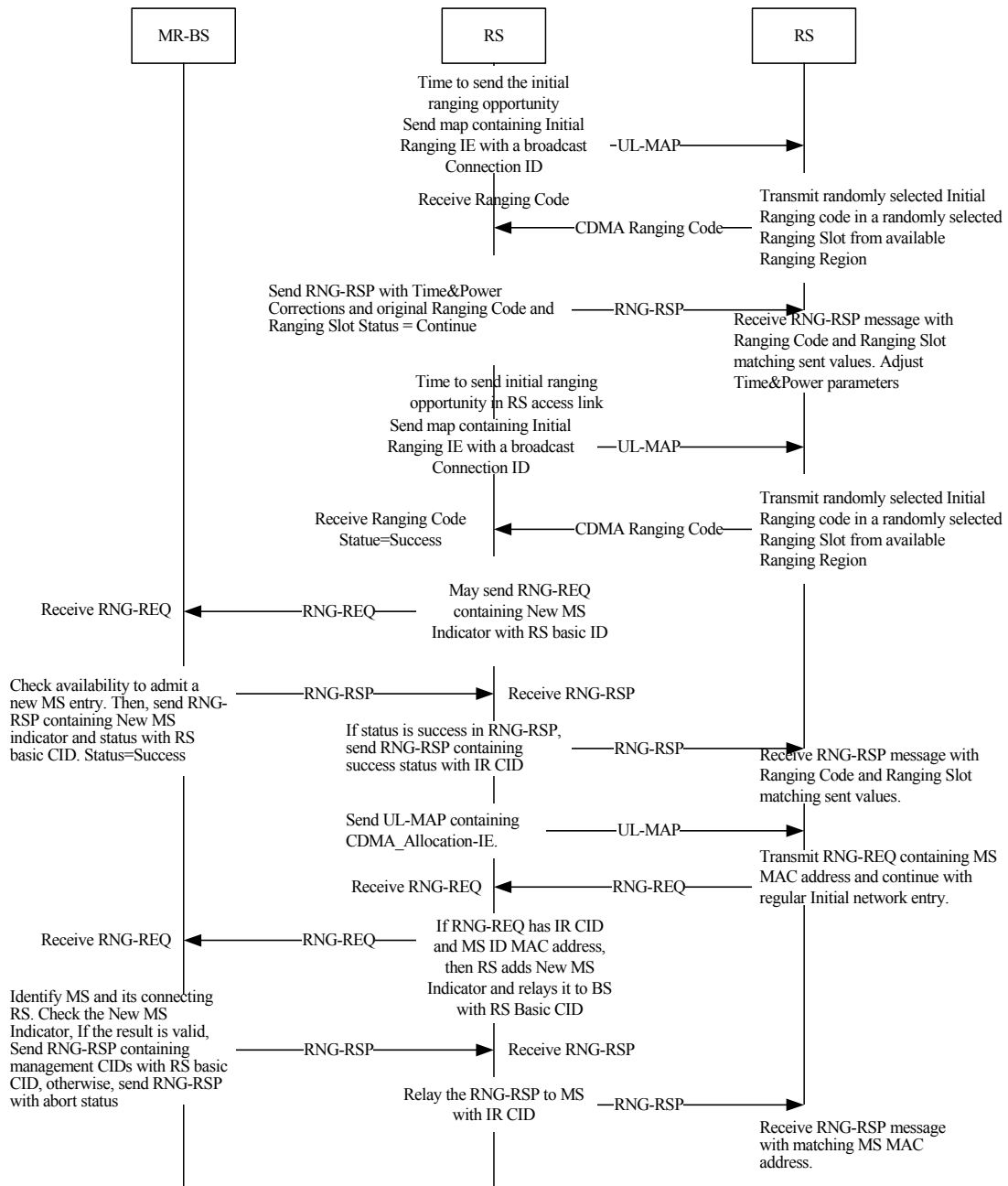

Figure <XXX>03—Ranging and automatic adjustments procedure with optional availability check at MR-BS in MR mode

6.3.10 Ranging

6.3.10.3 OFDMA based ranging

Insert new subclause 6.3.10.3.4:

6.3.10.3.4 Relaying support for OFDMA based ranging

Insert new subclause 6.3.10.3.5:

6.3.10.3.5 Ranging in relay networks with centralized bandwidth allocation

In relay networks with centralized bandwidth allocation, the MR-BS shall assign unique CDMA ranging codes to each RS in its MR-cell so that it can immediately determine the purpose and the originator of the code. These codes allow the RS to quickly inform the MR-BS that it is engaged in a ranging process with one of its downstream stations and receive bandwidth from the MR-BS on which to continue or complete the process.

The RS may be assigned several unique CDMA ranging codes for the purpose of supporting various ranging processes. The codes that may be assigned to the RS to communicate different requests to the MR-BS are:

- 1) Indicate that the RS needs BW on its access downlink on which to transmit a RNG-RSP message with “continue” status
- 2) Indicate that the RS needs a BW allocation on the relay uplinks along the path to the MR-BS on which to transmit a BW request *message*.
- 3) Indicate that the RS needs BW on its *relay* downlink (i.e. to its downstream RS) on which to transmit a RNG-RSP message with “continue” status
- 4) Indicate that the RS needs BW allocations on the relay uplinks along the path to the MR-BS on which to forward a BW request *header*.

6.3.11 Update of channel descriptors

6.3.12 Assigning SSs to multicast groups

6.3.13 Establishment of multicast and broadcast transport connections

6.3.14 QoS

6.3.14.2 Service flows

Insert the following text at the end of section 6.3.14.2:

In MR networks, a service flow may traverse one or more RSs.

Insert new subclause 6.3.14.10:

6.3.14.10 Tunnel Service Flows

In MR networks, a tunnel connection may be established to carry MPDUs from individual service flows. A tunnel connection is a unidirectional connection between the MR-BS and an RS (in either direction) that is used to carry MPDUs from a set of service flows assigned to traverse the tunnel. Each tunnel shall be assigned a Service Flow identifier (SFID) and a connection identifier (CID). The SFID is 32 bits and

1 uniquely identifies the tunnel and its QoS parameters within the MR Cell. The CID is assigned in the same
2 way as CIDs are assigned to service flows and is drawn from the same space as CIDs assigned to individual
3 service flow, however, a specific range of CIDs is assigned to support tunnels.
4

5
6 A service flow established between the MR-BS and MS may traverse a tunnel between the MR-BS and the
7 Access RS. (The access RS is the RS with which the MS communicates over an access link). A service flow
8 which traverses a tunnel shall be assigned an SFID and a CID, as specified in sections 6.3.14.1 through
9 6.3.14.9. In addition, the QoS parameters of the service flow are included in the QoS parameters of the tun-
10 nel. The QoS parameters of the tunnel are an aggregate of the QoS parameters of the service flows that have
11 been assigned to traverse the tunnel.
12

13
14 When a new service flow is created, the MR-BS or access RS determines whether the service flow should
15 traverse a tunnel that exists between them (if such a tunnel has been established). If the service flow is to
16 traverse the tunnel, the MR-BS or Access RS modifies the QoS parameters of the tunnel to include QoS
17 requirements of the service flow. The QoS parameters of both the tunnel and service flow are sent as part of
18 the connection setup messages (DS* messages). The Access RS and MR-BS use the QoS parameters of both
19 the individual service flow and the tunnel in performing admission control and resource reservation, while
20 intermediate RSs traversed by the tunnel, may ignore the QoS parameters of the individual service flows.
21
22

23 **6.3.17 MAC support for HARQ**

24 **6.3.18 DL CINR report operation**

25
26
27
28 *Insert new subclause 6.3.18.3:*
29

30 **6.3.18.3 Relay station DL CINR report operations**

31 **6.3.19 optional Band AMC operations using 6-bit CQICH encoding**

32 **6.3.21 Sleep mode for mobility-supporting MS**

33
34
35
36
37
38
39
40 *Insert new subclause 6.3.21.7:*
41

42 **6.3.21.7 Relay support for MS sleep mode**

43
44
45 In MR networks, the sleep mode shall be centrally controlled by the MR-BS in the presence of centralized or
46 distributed scheduling.
47

48
49
50 *Insert new subclause 6.3.21.7.1:*
51

52 **6.3.21.7.1 MS sleep mode support for centralized scheduling approach**

53
54
55 For an MS attached to the MR-BS through an RS, MS sleep mode operates as defined in section 6.3.21. All
56 MOB_SLP-REQ messages generated by MSs attached to an RS shall be relayed to the MR-BS. The MR-BS
57 shall be responsible for generating MOB_SLP-RSP messages, which will be relayed by RSs, either in
58 response to a MOB_SLP-REQ or unsolicited. The MR-BS shall take the additional relay delay into account
59 while it forwards the packets through RS.

6.3.22 MAC layer handover procedures

6.3.22.1 Network topology acquisition

6.3.22.1.1 Network topology advertisement

Insert the following at the end of subclause 6.3.22.1.1:

The MR-BS and the RS shall broadcast information about the infrastructure stations that are present in the network using the MOB_NBR-ADV message defined in 6.3.2.3.47. The MR-BS and the RS may obtain the information to be included in the MOB_NBR-ADV message over the backbone network or over the relay links. Each RS can broadcast a different MOB_NBR-ADV message that is suitable for its service area.

To facilitate each RS to transmit a MOB_NBR-ADV message suitable for its service area, the MR-BS shall transmit a MR_NBR-INFO message to the RSs. The MR_NBR-INFO is a customized, unicast message that is composed by the MR-BS according to the specific neighborhood of the receiving RS. The MR_NBR-INFO message is transmitted by the MR-BS to the RSs over the relay links. In order to compose the MR_NBR-INFO customized for the subordinate RSs, the MR-BS can use location information or the interference measurement reports received from the infrastructure stations.

An RS, depending on its capability and depending on the messages that it receives, can choose between one of the following options in generating the MOB_NBR-ADV message:

(a) An RS can broadcast the MOB_NBR-ADV message without modifying the neighbor list of the MR_NBRINFO message, received from the MR-BS.

(b) An RS can further customize and compose a MOB_NBR-ADV message that is suitable for its service area by utilizing the information present in the MR_NBR-INFO messages received from the MR-BS.

Insert new subclause 6.3.22.4:

6.3.22.4 Mobile relay station handover

Insert new subclause 6.3.22.5:

6.3.22.5 MS handover procedure involving RS

An MS, connected through an RS or MR-BS, shall follow the same procedures as described for an MS handover in section 6.3.22.2.

Insert new subclause 6.3.22.5.1:

6.3.22.5.1 MS Movement among access stations with different preamble/FCH/MAP

The fixed RS or nomadic RS shall relay HO related management messages between MS and MR-BS.

Insert new subclause 6.3.22.5.2:

6.3.22.5.2 MS Movement among access stations with same preamble/FCH/MAP

In this case, MS is not aware of the HO. Therefore, RS and MR-BS shall perform measurement of MS signal quality to assist MS movement among stations (RSs, MRBS) that share the same preamble/FCH/MAP.

6.3.23 Multicast and broadcast services (MBS)

6.3.23.1 Single-BS access

6.3.23.2 Multi-BS access

Insert new subclause 6.3.23.3:

6.3.23.3 MBS in MR network

For MR networks, MBS transmission within an MBS zone shall be synchronized. In Multi-MR-BS-MBS case, MR-BSs should be synchronized in network level as described in section 6.3.23.2.

If there is only one RS connecting with the MR-BS, that RS shall report its processing delay (in units of a frame), DR, to the MR-BS as a capability parameter in the SBC-REQ message. When an MBS transmission is necessary, the MR-BS shall first send the MBS data over the relay downlink as a pre-transmission, and then after DR frames, the MR-BS and RS shall synchronously transmit this MBS data over the access link.

If there are multiple RSs in the MBS zone at various hop counts from the MR-BS and/or with different processing delays, each RS shall report its processing delay, DR, to the MR-BS as a capability parameter in the SBC-REQ message. The MR-BS shall determine the maximum cumulative delay, DM, of all RSs in the MBS zone based on their positions in the tree and their individual processing delays. The MR-BS shall then calculate the required waiting time, W_i , for each RS based on the value of DM and each RS's cumulative delay and notify each RS of its waiting time via an SBC-RSP message. If the MR-BS detects that the waiting time has changed for a particular RS, it may send an unsolicited SBC-RSP message to that RS to update its waiting time.

When an MBS transmission is necessary, the MR-BS shall forward the MBS data over the relay downlink as a pre-transmission DM frames before transmitting this MBS data over the access link. Each RS in the MBS zone shall forward the MBS data it receives over the relay downlink. Finally, once the MR-BS has waited DM frames and each RS has waited its specified waiting time, W_i , the MR-BS and RSs shall synchronously transmit the MBS data over the access link.

6.3.24 MS Idle Mode (optional)

Insert the following text after the third paragraph:

FRS and NRS may have same or different Paging Groups compared to controlling MMR-BS. MRS shall be assigned one or more Paging Groups, which shall be different from MMR-BS.

6.3.24.8.2 Location Update Process

Insert the following text after the first paragraph:

When MS initiate location update process via Mobile RS, MR-BS may allocate PG ID to MS same as MRS.

Insert new subclause 6.3.24.10:

6.3.24.10 MRS Paging Group Update

This process is only applicable to MRS. In principle, triggers and process for MRS Paging Group Update is similar to MS location update. However, MS location update is performed in idle mode where as MRS does not have idle mode. MRS shall perform the paging group update procedure with MMR-BS when the MRS detects a change in paging group. MRS shall detect the change of paging group by monitoring the paging group identifier, PG_ID, which is transmitted by the preferred BS in the DCD message or MOB_PAG_ADV broadcast message. If the PG_ID detected does not match the Paging Group to which MRS belongs, the RS shall perform the Paging Group update process with MMR-BS.

Insert new subclause 6.3.24.10.1

6.3.24.10.1 Paging Group Update process

If MRS determines to update its location, depending on the security association the MRS shares with the target MMR-BS, the MRS shall use one of the two processes: Secure MRS Paging Group Update Process or Unsecured MRS Paging Group Update Process.

Insert new subclause 6.3.24.10.1.1:

6.3.24.10.1.1 Secure Paging Group Update process

If the MRS shares a valid security context with the target BS such that the MRS may include a valid HMAC/CMAC Tuple in the RNG-REQ, then the MRS shall conduct initial ranging with the target BS by sending a RNG-REQ including Ranging Purpose Indication TLV with Bit #2 set to 1, Paging Group Update Request and RS Paging Group ID TLVs and HMAC/CMAC Tuple. If the target BS evaluates the HMAC/CMAC Tuple as valid and can supply a corresponding authenticating HMAC/CMAC Tuple, and wants to add RS PG_ID to its PG_ID list based on the policy out of the scope of standard, target BS may exchange backbone messages with the other BSs in its PG to request the addition of RS PG_ID to their PG_ID list. Upon successful response from all of the BSs, the target BS shall reply with the RNG-RSP including the Paging Group Update Response TLV and HMAC/CMAC Tuple completing the Paging Group Update process. If the target BS responds with a successful Paging Group Update Response=0x01, Success of Paging Group Update, the target BS shall notify the Paging Controller via the backbone of the MRS new location information, and the Paging Controller may send a backbone message to inform the BSs to which the MRS was earlier attached that the MRS has transitioned to a different Paging Group. If the target BS evaluates the HMAC/CMAC Tuple as invalid, cannot supply a corresponding authenticating HMAC/CMAC Tuple, or otherwise elects to direct the MRS to use Unsecured Paging Group Update, then the target BS shall instruct the MRS to continue network reentry using the Unsecured Paging Group Update process by inclusion of Paging Group Update Response TLV in RNG-RSP with a value of 0x00= Failure of Paging Group Update.

Insert new subclause 6.3.24.10.2:

6.3.24.10.2 Unsecured Paging Group Update process

For an MRS and target BS that do not share current, valid security context, they shall process Paging Group Update using the Network Re-Entry.

Insert new subclause 6.3.24.11:

6.3.24.11 Network Re-Entry for MRS Paging Group Update

For the Network Re-Entry, the MRS shall initiate network re-entry with the target BS by sending a RNG-REQ including Ranging Purpose Indication TLV with Bit #2 set to 1, Paging Group Update Request and RS Paging Group ID TLVs.

If the MRS shares a valid security context with the target BS such that the MRS may include a valid HMAC/CMAC Tuple in the RNG-REQ, then the MRS shall conduct initial ranging with the target BS by sending a RNG-REQ including HMAC/CMAC Tuple.

If MRS RNG-REQ includes a Ranging Purpose Indication TLV with Bit #2 set to 1 and Paging Group ID TLVs, and target BS had not previously received MRS information over the backbone, then target BS may make an MRS information request to Paging Controller over the backbone network and Paging Controller may respond. Regardless of having received MRS information from Paging Controller, target BS may request MRS information from another network management entity via the backbone network.

Network re-entry proceeds per 6.3.9.5 except as may be shortened by target BS possession of MRS information obtained from Paging Controller or other network entity over the backbone network. Rest of the network entry procedure for MRS is similar to MS as defined in section 6.3.24.9.

Insert new subclause 6.3.25:

6.3.25 Relay path management and routing

Insert new subclause 6.3.26:

6.3.26 Relay station neighborhood discovery

Insert new subclause 6.3.27:

6.3.27 Interference measurement for MR

This subclause describes a measurement and reporting procedure with supported messaging mechanism to estimate the interference level in MR network.

7. Security sublayer

7.1 Architecture

7.2 PKM protocol

7.3 Dynamic SA creation and mapping

7.4 Key usage

7.5 Cryptographic methods

7.6 Certification profile

7.7 Pre-Authentication

7.8 PKMv2

8. PHY

8.4 WirelessMAN-OFDMA PHY layer

8.4.1 Introduction

8.4.4 Frame structure

Insert new subclause 8.4.4.7:

8.4.4.7 Frame structure of MR-BS and RS

This section describes the minimal requirements for an in-band frame structure for a MR-BS and its subordinate RS.

Insert new subclause 8.4.4.7.1:

8.4.4.7.1 Frame structure for transparent mode

Insert new subclause 8.4.4.7.1.1:

8.4.4.7.1.1 MR-BS frame structure

For the TDD mode, an example of the MR-BS frame structure is shown in Figure xxx.

Each frame in the downlink transmission begins with a preamble followed by an FCH, DL-MAP, and possibly UL-MAP. R-MAP is located following MAP or defined as an extension of MAP. The frame structure

consists of DL sub-frame period and UL sub-frame period. In each frame, the TTG shall be inserted between the DL sub-frame and the UL sub-frame. The RTG shall be inserted at the end of each frame.

The common ranging subchannel is shared by all RSs and MSs within one MR-cell.

The DL sub-frame shall include at least one zone for MR-BS to its subordinate MS/RS transmissions and may optionally include a transparent zone for RS to its subordinate stations transmissions. Optionally the MR-BS may transmit in the transparent zone as well. The transparent zone can be indicated by STC_DL_ZONE_IE() defined in Table 279. The UL sub-frame may include a zone for MS to its access station transmissions and optionally include a zone for RS to its access station transmissions. The bandwidth allocation for transmissions between MR-BS and MS / RS follows IEEE802.16e operation.

Figure <xxx>—Example of configuration for an in-band transparent relay frame structure

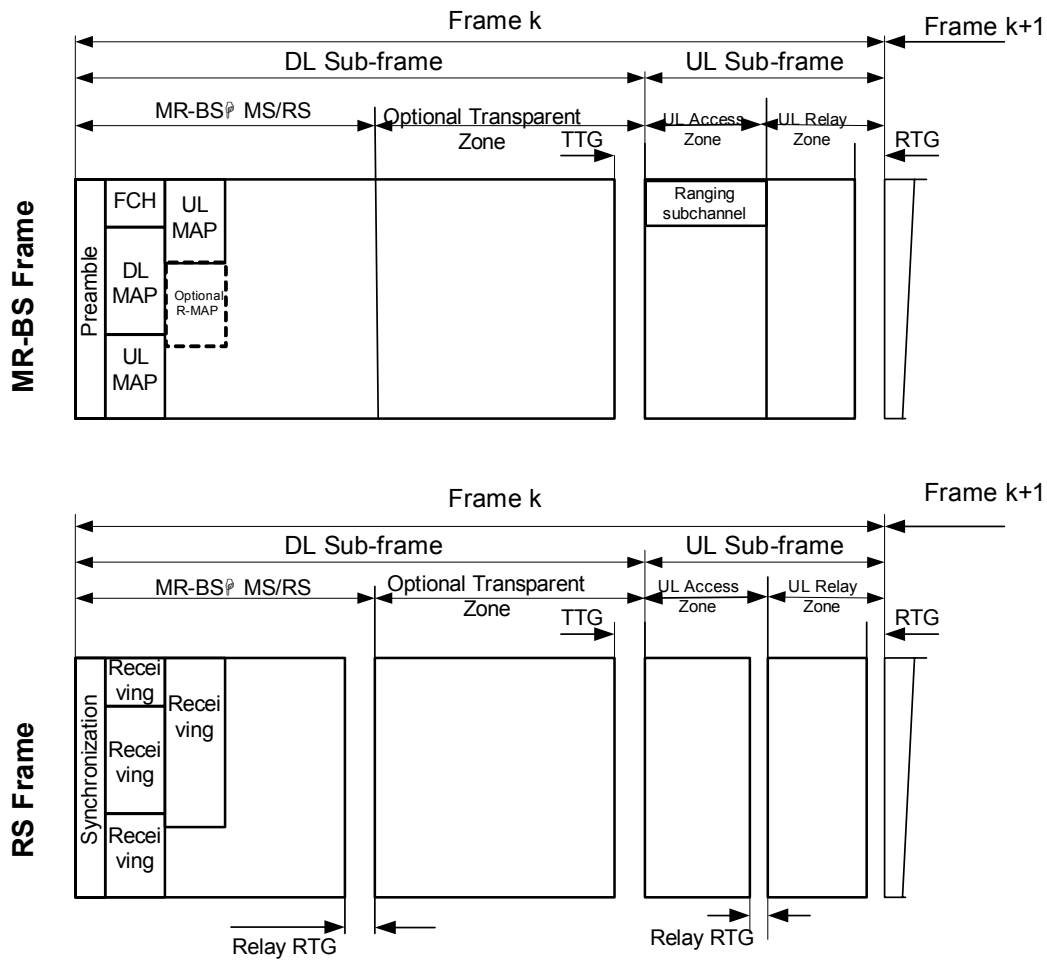

Insert new subclause 8.4.4.7.1.2:

8.4.4.7.1.2 Relay frame structure

From RS view, an example of an RS TDD frame structure is shown in Figure xxx.

For a transparent relay RS, the preamble and MAP are not transmitted at the beginning of the frame. Instead it listens the preamble, MAP or optional R-MAP transmission from MR-BS. The detailed allocation for RS

1 can be indicated by MAP or R-MAP. The signaling method shall be negotiated in RS network entry procedure. In each frame, the TTG shall be inserted between the DL sub-frame and the UL sub-frame. The RTG shall be inserted at the end of each frame.

2
3
4
5 The DL sub-frame shall include one zone for RS and MS to receive burst from MR-BS and optionally include a transparent zone for RS to transmit burst to its subordinate stations. The UL sub-frame may include zero or one zone for receiving burst from its subordinate stations and zero or one zone for transmitting burst to MR-BS/RS. The ranging channel is shared by RS and MS, while RS may indicate itself as relay during the initialization. Optionally, an RS amble (at TBD location) may be transmitted.

6
7
8
9
10
11
12 If the RS switches from transmission to reception mode, an R-TTG shall be inserted. If the RS switches from reception to transmission mode, an R-RTG shall be inserted.

13
14
15 Simultaneous operation of transparent RSs and non-transparent RSs within one MR-cell can be supported by allocating relay zones within the transparent relay frame structure.

16
17
18 *Insert new subclause 8.4.4.7.2:*

19 **8.4.4.7.2 Frame structure for non-transparent mode**

20
21
22 For the case where MR-BS supports two-hop relay, the DL and UL subframes shall include at least one access zone and may include one or more relay zone to enable RS operating in either transmit or receive mode.

23
24
25
26
27 Two approaches for supporting more than two hop relaying are specified. An RS shall be capable of being configured to support either one of the operations, but shall not be required to support both operations simultaneously.

28
29
30
31
32 The first approach allows one or more RS or MR-BS frames to be grouped into a multi-frame with a repeating pattern of allocated relay zones. The MR-BS and RSs are assigned to transmit, receive or be idle in each of the relay zones within the multi-frame. As an example, a two-frame multi-frame can be used to assign odd hop RSs to transmit in the DL Relay Zone of odd number frames and the MR-BS and even hop RSs to transmit in the DL Relay Zone of even number frames.

33
34
35
36
37
38 The second approach enables a single-frame frame structure consisting of more than one Relay zones. The MR-BS and RSs are assigned to transmit, receive, or be idle in each relay zone within the frame. As an example, the odd hop RSs can be assigned to transmit in one DL Relay Zone, while the MR-BS and even op RSs can be assigned to transmit in another DL relay zone.

39
40
41
42
43
44 *Insert new subclause 8.4.4.7.2.1:*

45 **8.4.4.7.2.1 MR-BS frame structure**

46
47
48 For the TDD mode, an example of the MR-BS frame structure is shown in Figure <xxx>.

49
50
51 Each MR-BS frame begins with a preamble followed by an FCH and the DL MAP and possibly UL MAP. The DL sub-frame shall include at least one DL Access_Zone and may include one or more DL Relay_Zones. The UL sub-frame may include one or more UL Access_Zones and it may include one or more UL Relay_Zones. A relay zone may be utilized for either transmission or reception but the MR-BS shall not be required to support both modes of operation within the same zone. In each frame, the TTG shall be inserted between the DL sub-frame and the UL sub-frame. The RTG shall be inserted at the end of each frame. In the DL Access_Zone, the subchannel allocation, the FCH transmission, and the FCH shall be defined as in Section 8.4.4.2.

The DL Relay_Zone shall include a R-FCH and a R-MAP. In the DL Relay_Zone, the subchannel allocation may be the same as that in the DL Access_Zone. The R-FCH may be the same as the FCH in the DL Access_Zone. Other attributes of the MR-BS frame and the RS frame such as transition between modulation and coding presence of multiple zones, may be the same as those described in 8.4.4.2.

The number, size, and location of the relay zones shall be configurable.

Figure <xxx>—Example of minimum configuration for an in-band non-transparent relay frame structure

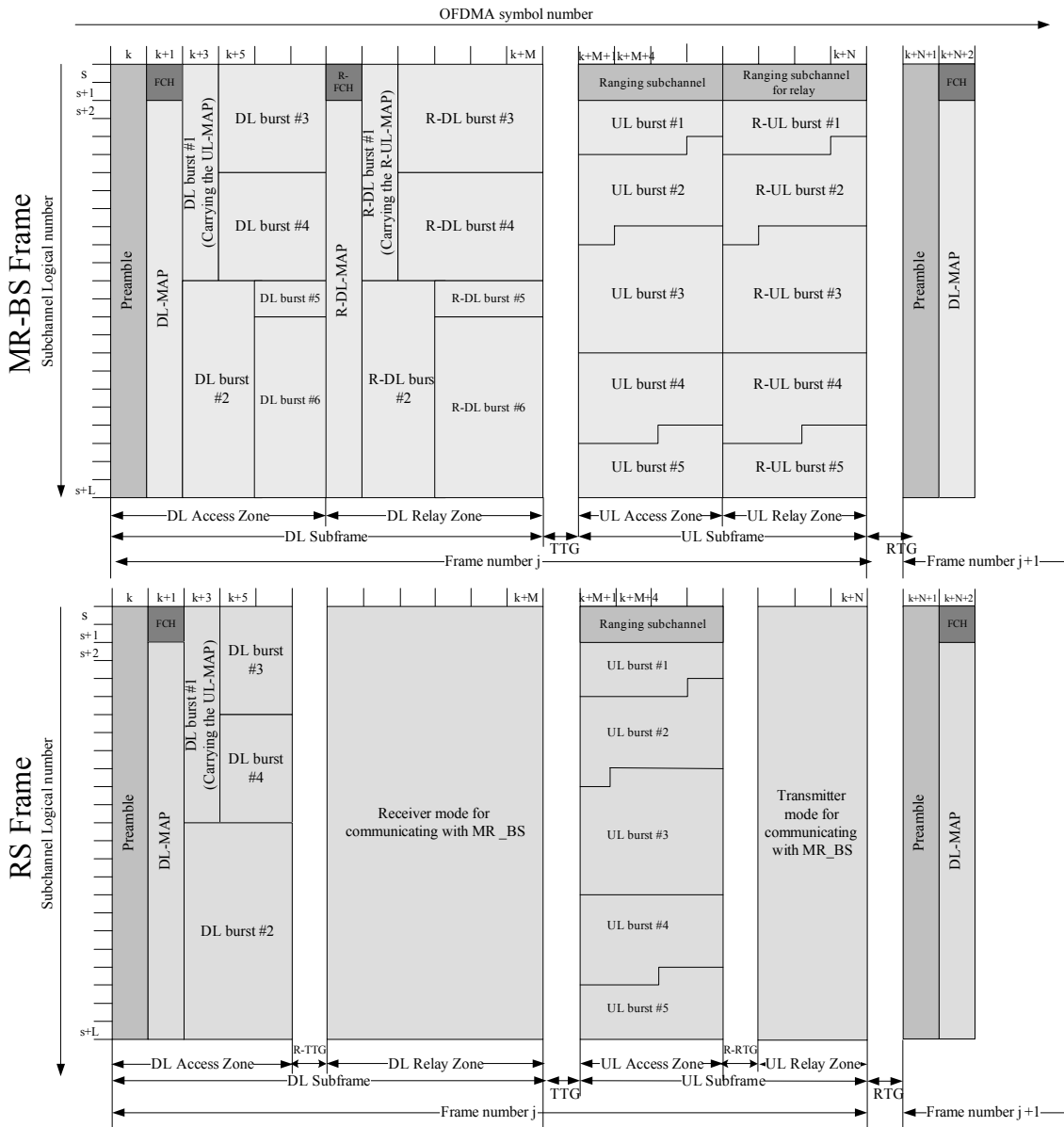

Insert new subclause 8.4.4.7.2.2:

8.4.4.7.2.2 Relay frame structure

For the TDD mode, an example of an RS frame structure is shown in Figure <xxx> .

1 The Relay Station transmits its frame start preamble time aligned with its serving MR-BS frame start preamble.
2
3

4 The DL sub-frame shall include at least one DL Access_Zone and may include one or more ~~DL~~ Relay_Zones. An R-TTG may be placed between a DL Access_Zone and a DL Relay_Zone ~~and an R-TTG~~
5 ~~or R-RTG may be placed between two adjacent DL Relay_Zones.~~
6
7

8
9 The UL sub-frame may include one or more UL Access_Zones and one or more ~~UL~~ Relay_Zones. An R-RTG may be placed between a UL Access_Zone and a UL Relay_Zone ~~and an R-TTG or R-RTG may be~~
10 ~~inserted between two adjacent UL Relay_Zones.~~
11

12
13 A relay zone may be utilized for either transmission or reception but the RS shall not be required to support
14 both modes of operation within the same zone.
15

16
17 If the relay station switches from transmission to reception mode, an R-TTG ~~shall~~ may be required. If the
18 relay station switches from reception to transmission mode, an R-RTG ~~shall~~ may be required. There may be
19 more than one R-TTG and more than one R-RTG inserted in the RS frame. In each frame, the TTG shall be
20 inserted between the DL sub-frame and the UL sub-frame. The RTG shall be inserted at the end of each
21 frame.
22

23
24 The contents of the FCH, DL-MAP and UL-MAP in the Relay Frame may be different from those in the
25 MR-BS frame.
26

27 Each RS frame begins with a preamble followed by an FCH and the DL-MAP and possibly a UL-MAP. In
28 the DL Access_Zone, the subchannel allocation, the FCH transmission, and the FCH shall be as defined in
29 Section 8.4.4.2.
30

31
32 The number, size, and location of the relay zones ~~and whether the RS is utilizing the relay zone for transmis-~~
33 ~~sion or reception~~ shall be configurable. ~~The number of frames that make up a multi-frame shall be config-~~
34 ~~urable.~~
35

36
37 *Insert new subclause 8.4.4.8:*
38

39 **8.4.4.8 Relaying frame structure**

40 **8.4.5 Map message fields and IEs**

41 **8.4.7 OFDMA ranging**

42 **8.4.8 Space-Time Coding (optional)**

43
44
45
46
47
48
49
50 *Insert new subclause 8.4.8.10:*
51

52 **8.4.8.1 Cooperative Relaying**

53
54 Cooperative relaying can be achieved within an MR-BS cell with BS and RS transmit cooperation, in the
55 same manner as macro diversity with neighboring BS. It is possible to achieve diversity and solve the pilot
56 collision problem by sending correlated signals across different BS and RS transmit antennas during the
57 transmission of a burst to a particular MS. The three modes of operation are cooperative source diversity,
58 cooperative transmit diversity, and cooperative hybrid diversity.
59

1 In the following description, the transmission considered is the final hop from the multiple antennas at the
2 BS/RS to the MS. For cooperative source diversity, the antennas simultaneously transmit the same signal
3 using the same time-frequency resource. The cooperative transmit diversity mechanism uses STBC-encoded
4 signals across the transmitting antennas using the same time-frequency resource (refer to Section 8.4.8 for a
5 list of valid STBCs). Cooperative hybrid diversity uses a combination of source and transmit diversity.
6

7
8 These mechanisms can each be further subdivided into two categories describing the processing requirement
9 at the RS. The relayed data at the RS may not require processing, which we have called Full Encoding (i.e.
10 during the backhaul hop, the BS transmits the exact signals for the RS to relay). Alternately, the relayed data
11 at the RS may require some local processing, which we have called Half Encoding (the backhaul hop con-
12 tains uncoded data, and the RS decodes and re-encodes the data according to the STBC in use). In this last
13 category, each RS shall be notified of its virtual antenna number(s).
14

15 **8.4.9 Channel coding**

16 **8.4.10 Control mechanisms**

17
18 *Insert new subclause 8.4.10.4:*

19 **8.4.10.4 Power control in MR networks**

20
21 A power control algorithm shall be supported in MR networks for the uplink channels from RSs and SSs
22 with both an initial calibration and periodic adjustment procedure without loss of data. Power control of the
23 RS downlink channels shall also be supported.
24

25
26 In the case of centralized MR, the UL power control algorithm shall be located in the MR-BS and the MR-
27 BS shall control the transmit power on all uplink channels served by the MR-BS and its subordinate RSs. In
28 the case of distributed MR, an UL power control algorithm shall be located in both the MR-BS and RSs to
29 control the uplink channels it serves.
30

31
32 The response of the SS to power control messages received from the MR-BS or RS is described in subclause
33 8.4.10.3. This subclause defines how the RS responds to power control messages from the MR-BS and how
34 the MR-BS and RS control the transmit power in MR networks.
35

36
37 The following subclauses describe the power control mechanism for both centralized and distributed cases.
38

39
40 *Insert new subclause 8.4.10.4.1:*

41 **8.4.10.4.1 Power control of RS**

42
43 The RS shall respond to UL power control messages from the MR-BS or RS in the same way an SS responds
44 to power control messages, as specified in subclause 8.4.10.3. The RS shall also be capable of receiving DL
45 power control messages from the MR-BS or RS. DL power control messages define the maximum DL trans-
46 mit power that the RS is allowed to use.
47

48
49 *Insert new subclause 8.4.10.4.2:*

50 **8.4.10.4.2 Power control of SS in centralized MR**

51
52 In the centralized MR network the MR-BS shall generate the power control messages for the SS and trans-
53 mit them to the SS via the RS. RSs shall have the capability to report the channel quality measurement infor-
54 mation of their access-uplink channels to an MR-BS or superordinate RS. The SS shall respond to power
55
56
57
58
59

control messages in the manner described in 8.4.10.3. The MR-BS shall also be responsible for controlling the DL transmit power used at all subordinate RSs.

Insert new subclause 8.4.10.4.3:

8.4.10.4.3 Power control of SS in distributed MR

In the distributed MR network, the RS shall generate the power control messages for the SSs that it serves. The SS shall respond to power control messages in the manner described in 8.4.10.3.

8.4.11 Channel quality measurements

8.4.12 Transmitter requirements

8.4.13 Receiver requirements

8.4.14 Frequency control requirements

8.4.15 Optional HARQ support

9. Configuration

Insert new subclause 9.3:

9.3 MR-BS configuration

Insert new subclause 9.4:

9.4 RS configuration

10. Parameters and constants

10.1 Global values

Change Table 342 as indicated:

Table 342—Parameters and constants

| System | Name | Time Reference | Minimum value | Default value | Maximum value |
|-----------------------|---------------------|--|---------------------|---------------------|---------------|
| MR-BS | T48 | Wait for RNG-REQ from the subordinate RS | tbd | tbd | |

1
2
3
4
5
6
7
8
9
10
11
12
13
14
15
16
17
18
19
20
21
22
23
24
25
26
27
28
29
30
31
32
33
34
35
36
37
38
39
40
41
42
43
44
45
46
47
48
49
50
51
52
53
54
55
56
57
58
59

10.2 PKM parameter values

10.3 PHY-specific values

Insert new subclause 10.3.5:

10.3.5 Relay mode PHY parameters and definitions

10.4 Well-known addresses and identifiers

Change Table 345 as indicated:

Table 345—CIDs

| CID | Value | Description |
|---------------------------------------|--------------------------|--|
| Initial Ranging | 0x0000 | Used by SS and BS during initial ranging process. |
| Basic CID | 0x0001 - m | The same value is assigned to both the DL and UL connection. |
| Primary management | $m+1 - 2m$ | The same value is assigned to both the DL and UL connection. |
| Tunnel CID | 2m+1 - n | Used by MMR-BS or RS for tunneling transport connection packet. |
| Management Tunnel CID | n+1 - p | Used by MMR-BS or RS for tunneling management connection packets. |
| Transport CIDs, Secondary Mgt CIDs | $p-2m+1 - FE9F$ | For the secondary management connection, the same value is assigned to both the DL and UL connection. |
| Multicast CIDs | 0xFEA0 - 0xFEFE | For the downlink multicast service, the same value is assigned to all MSs on the same channel that participate in this connection. |
| AAS initial ranging CID | 0xFEFF | A BS supporting AAS shall use this CID when allocating a an ASS AAS Initial Ranging period (using AAS Ranging Allocation IE) |
| Multicast polling CIDs | 0xFF00 - 0xFFF9 | A BS may be included in one or more multicast polling groups for the purposes of obtaining bandwidth via polling. These connections have no associated service flow. |
| Normal mode multicast CID | 0xFFFA | Used in DL-MAP to denote bursts for transmission of DL broadcast information to normal mode MS. |
| Sleep mode multicast CID | 0xFFFB | Used in DL-MAP to denote bursts for transmission of DL broadcast information to Sleep mode MS. May also be used in MOB_TRF-IND messages. |
| Idle mode multicast CID | 0xFFFC | Used in DL-MAP to denote bursts for transmission of DL broadcast information to Idle mode MS. May also be used in MOB_PAG-ADV messages. |
| Fragmentable Broadcast CID | 0xFFFD | Used by the BS for transmission of management broadcast information with fragmentation. The fragment sub header shall use 11-bit long FSN on this connection. |
| Padding CID | 0xFFFE | Used for transmission of padding information by SS and BS. |
| Broadcast CID | 0xFFFF | Used for broadcast information that is transmitted on a downlink to all SS. |

11. TLV Encodings

11.5 RNG-REQ message encodings

Change Table 364 as indicated:

Table 364—RNG-REQ message encodings

| Name | Type (1 byte) | Length | Value (variable length) | PHY Scope |
|---|-----------------------|--------------------------|--|-----------------------|
| Ranging Purpose Indication | 6 | 1 | Bit #0: HO indication (when this bit is set to 1 in combination with other included information elements indicates the MS is currently attempting to HO or Network Re-entry from Idle Mode to the BS) Bit #1: Location Update Request (when this bit is set to 1, it indicates MS action of Idle Mode Location Update Process) Bit #2: MRS Location Update Request Bits 2 3-7: <i>Reserved</i> | |
| RS Type | = | <u>1</u> | 0: Fixed RS 1: Mobile RS 2-555: Reserved | |
| New MS Indication ID | TBA | <u>1</u> | Unique identifier assigned by RS for each MS under ranging process | |
| Received Ranging Codes | TBA | Variable | Received Ranging codes is a compound TLV value that indicates received code information | OFDMA |
| Timing Adjust | TBA.1 | <u>4</u> | Tx timing offset adjustment (signed 32-bit). The amount of time required to adjust SS transmission so the bursts will arrive at the expected time instance at the BS. Units are PHY specific (see 10.3). | OFDMA |
| Power Level Adjust | TBA.2 | <u>1</u> | Tx Power offset adjustment (signed 8-bit, 0.25 dB units) Specifies the relative change in transmission power level that the SS is to make in order that transmissions arrive at the BS at the desired power. When subchannelization is employed, the subscriber shall interpret the power offset adjustment as a required change to the transmitted power density. | OFDMA |
| Offset Frequency Adjust | TBA.3 | <u>4</u> | Tx frequency offset adjustment (signed 32-bit, Hz units). Specifies the relative change in transmission frequency that the SS is to make in order to better match the BS. (This is fine-frequency adjustment within a channel, not reassignment to a different channel.) | OFDMA |

Table 364—RNG-REQ message encodings

| | | | | |
|---|-----------------------|---------------------|---|-----------------------|
| Ranging Status | TBA.4 | 1 | Used to indicate whether uplink messages are received within acceptable limits by BS. 1 = continue, 2 = abort, 3 = success | OFDMA |
| Ranging code attributes | TBA.5 | 4 | Bits 31:22 - Used to indicate the OFDM time symbol reference that was used to transmit the ranging code. Bits 21:16 - Used to indicate the OFDMA sub-channel reference that was used to transmit the ranging code. Bits 15:8 - Used to indicate the ranging code index that was sent by the SS. Bits 7:0 - The 8 least significant bits of the frame number of the OFDMA frame where the SS sent the ranging code. | OFDMA |
| Channel Measurement Information | TBA.6 | TBA | TBD | |

11.6 RNG-RSP message encodings

Change Table 367 as indicated:

Table 367—RNG-RSP message encodings

| Name | Type (1 byte) | Length | Value (variable-length) |
|--------------------------------------|---------------------|-------------------|---|
| New MS Indication ID | TBA | 1 | New MS Indication ID from corresponding RNG-REQ from RS |

Insert new subclause 11.8.3.7.20:

11.8.3.7.20 RS maximum downlink transmit power

The maximum EIRP for the access DL preamble transmission at the RS. The RS will inform the MR-BS of the maximum EIRP that can be supported during network entry. The MR-BS will indicate to the RS the maximum EIRP the RS can utilize on the access DL preamble and advertise in any DCD message transmitted by the RS on the access link. The MR-BS may also send unsolicited SBC-RSP at any time to adjust the maximum EIRP that the RS may use, up to the maximum EIRP that the RS indicated during network entry. The maximum EIRP parameters are reported in dBm and quantized in 1dB steps ranging from [TBD]dBm (encoded 0x00) to [TBD]dBm (encoded 0xFF). Values outside this range shall be assigned the closest extreme.

| Type | Length | Value | Scope |
|------|--------|---------|--------------------|
| TBA | 1 | RS EIRP | SBC-REQ SBC-RSP |

1 *Insert new subclause 11.8.3.7.21:*

2
3 **11.8.3.7.21 RS Downlink Processing Delay**

4
5
6
7

| Type | Length | Value | Scope |
|------|--------|--|---------|
| TBA | 1 | RS Downlink Processing Delay (unit: frame) | SBC-REQ |

8
9
10
11

12
13 *Insert new subclause 11.8.3.7.22:*

14
15
16 **11.8.3.7.22 RS waiting time for MBS**

17
18
19

| Type | Length | Value | Scope |
|------|--------|---------------------------------------|---------|
| TBA | 1 | RS waiting time for MBS (unit: frame) | SBC-RSP |

20
21
22
23
24

25
26 *Insert new subclause 11.19.1:*

27
28 **11.19.1 CDMA Codes TLV**

29
30
31
32

| Name | Type (1 byte) | Length | Value |
|--------------|---------------|--------|---|
| RS CDMA Code | - | 4 | The TLV carries 4 byte ranging code in the following order - Ranging Request for SS (Continue) - Forward a Bandwidth Request Message from RS - Ranging Request for RS (Continue) - Forward a Bandwidth Request Header from RX |

33
34
35
36
37
38
39
40
41
42

43 *Insert new subclause 11.20.x:*

44
45 **11.20.x Tunnel CID and Management Tunnel CID**

46
47 For RS supporting tunnels, the T-CID and MT-CID are assigned in REG-RSP messages by the Serving BS.

48
49
50
51

| Type | Length (byte) | Value | Scope |
|------|---------------|----------------------------|---------|
| Xx | 2 | T-CID allocated to the RS | REG-RSP |
| Xx | 2 | MT-CID allocated to the RS | REG-RSP |

52
53
54
55
56
57
58
59

Insert new subclause 11.X:

11.X MR Code Report management message encodings

| Name | Type (1 byte) | Length | Value |
|-----------------|---------------|--------|---|
| Code attributes | TBA | 4 | Bits 31:22 - Used to indicate the OFDM time symbol reference that was used to transmit the ranging code. Bits 21:16 - Used to indicate the OFDMA subchannel reference that was used to transmit the ranging code. Bits 15:8 - Used to indicate the ranging code index that was sent by the SS or RS. Bits 7:0 - The 8 least significant bits of the frame number of the OFDMA frame where the SS sent the ranging code |

Insert new subclause 11.xx:

11.XX MR_NBR-INFO Management Message Encoding

| Name | Type (1 byte) | Length (bits) |
|--------------------------------|---------------|---------------|
| DCD Configuration Change count | 1 | 4 |
| UCD Configuration Change count | 2 | 4 |
| DCD settings | 3 | variable |
| UCD settings | 4 | variable |
| Neighbor BS trigger | 5 | variable |
| PHY Mode ID | 6 | 8 |